

ENSA®
Mofles
ESCAPES MONTERREY, S.A. DE C.V.

LA LÍNEA MÁS COMPLETA EN SISTEMAS DE ESCAPE Y CONVERTIDORES CATALÍTICOS

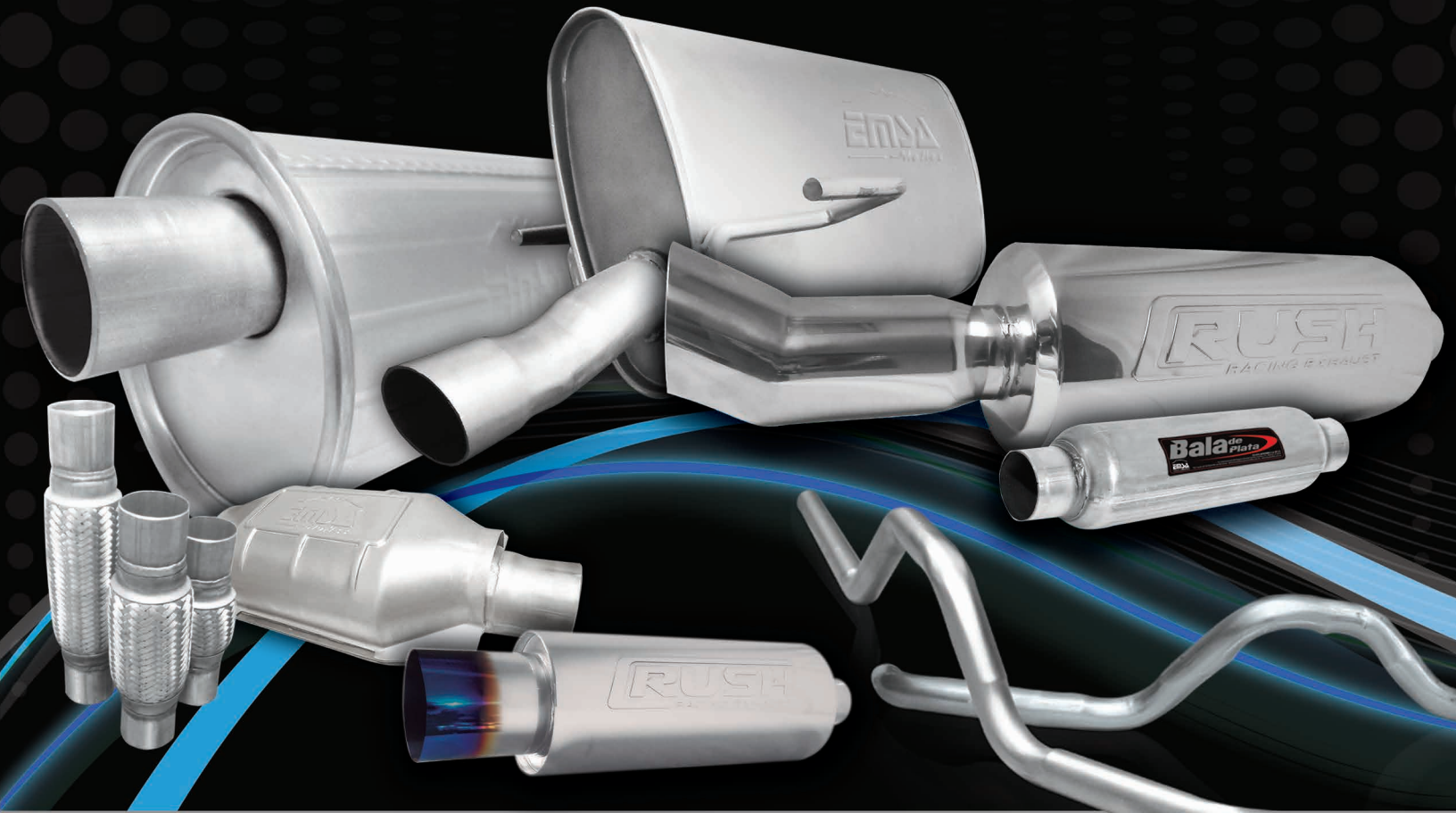

Originales • Universales • Balas • Convertidores Catalíticos • Alto rendimiento • Agrícola • Tubería recta/doblada • Accesorios

Líder en México y Mayor Exportador de Sistemas
de Escape de Repuesto en América Latina.





A 30 años del inicio de operaciones de **EMSA**, nos enorgullecen los logros alcanzados con tanto esfuerzo y dedicación; como el ser el Líder en sistemas de escape para repuesto en MEXICO y el principal exportador en LATINOAMERICA, nada de esto lo hubiéramos logrado sin el apoyo y lealtad de nuestros Clientes, Proveedores y Asociados, a los que agradecemos y Renovamos Nuestro Compromiso de continuar mejorando y seguir alcanzando los objetivos trazados.

*Una Empresa Líder
Orgullosamente Regiomontana*

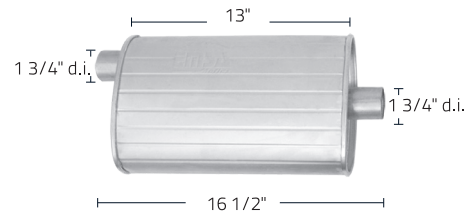
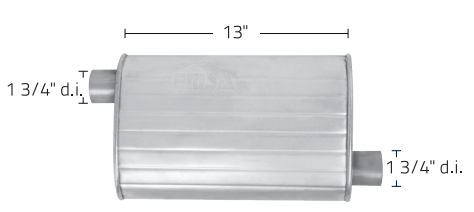
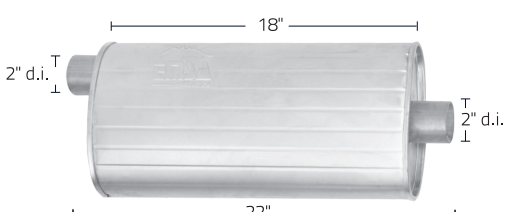
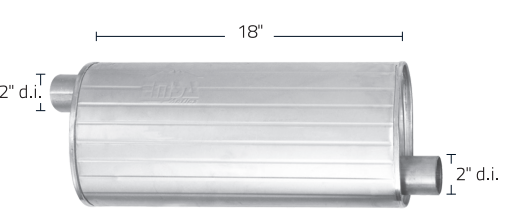
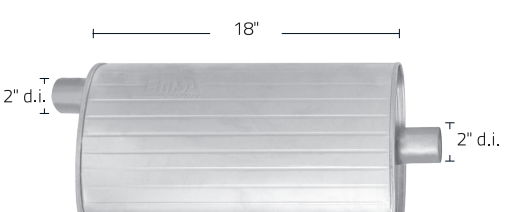
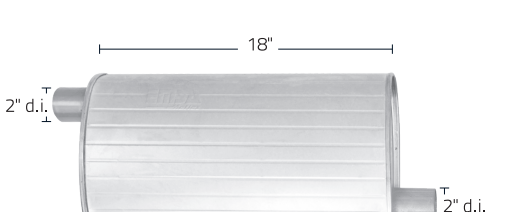

Modelo		Modelo	
S-3614-LL	<p>cuerpo calibre 20 aluminizado</p> <p>*d.i. diámetro interior *d.e. diámetro exterior</p> <p>⊕ 3 X 6"</p>	S-3618-H	<p>cuerpo calibre 20 aluminizado</p> <p>⊕ 3 X 6"</p>
	S-3618-LL		<p>Cuerpo calibre 20 aluminizado</p> <p>⊕ 3 X 6"</p>
S-618	<p>⊕ 6"</p>	S-621	<p>⊕ 6"</p>
S-624	<p>*d.i. diámetro interior *d.e. diámetro exterior</p> <p>⊕ 6"</p>	S-626	<p>⊕ 6"</p>
S-628	<p>⊕ 6"</p>	S-631	<p>⊕ 6"</p>

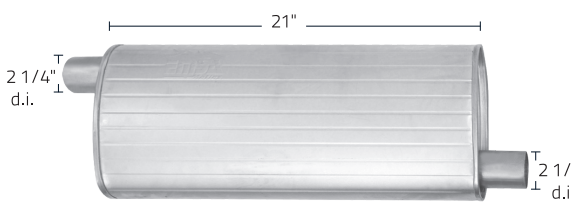
Modelo		Modelo	
S-713-LC	 <p>13" 1 3/4" d.i. 16 1/2" 1 3/4" d.i. ⊕ 4 X 7"</p>	S-713-LL	 <p>13" 1 3/4" d.i. 16 1/2" 1 3/4" d.i. ⊕ 4 X 7"</p>
S-718-LC	 <p>18" 2" d.i. 22" 2" d.i. ⊕ 4 X 7"</p>	S-718-LL	 <p>18" 2" d.i. 22" 2" d.i. ⊕ 4 X 7"</p>
S-918-LC	 <p>18" 2" d.i. 23" 2" d.i. ⊕ 4 X 9"</p>	S-918-LL	 <p>18" 2" d.i. 23" 2" d.i. ⊕ 4 X 9"</p>
S-921-LC	 <p>21" 2 1/4" d.i. 26" 2 1/4" d.i. ⊕ 4 X 9"</p>	S-921-LL	 <p>21" 2 1/4" d.i. 26" 2 1/4" d.i. ⊕ 4 X 9"</p>

Modelo

Modelo



*MODELOS EN CAJA

S-AL-612

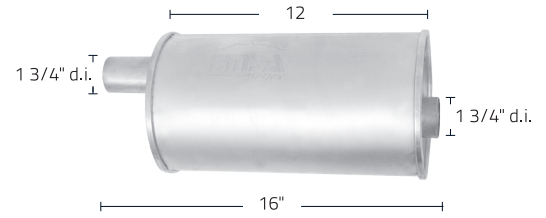

S-AL-618

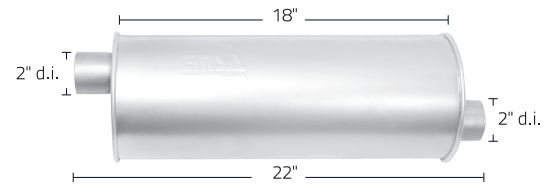

S-AL-621

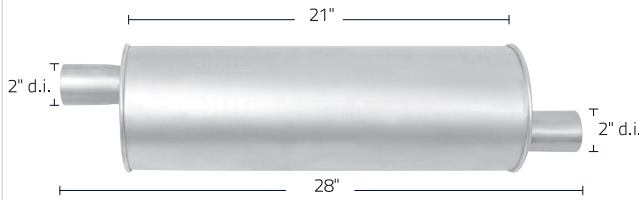

S-AL-624

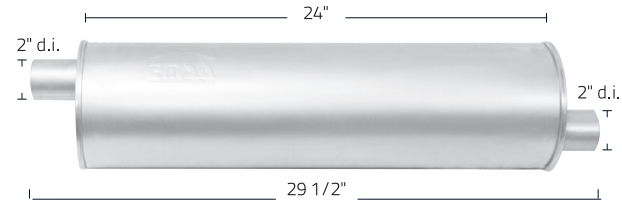

S-AL-626

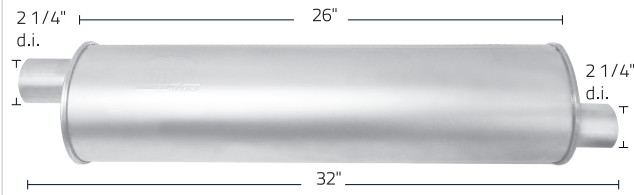

S-AL-628

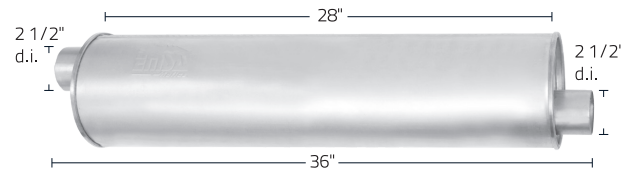

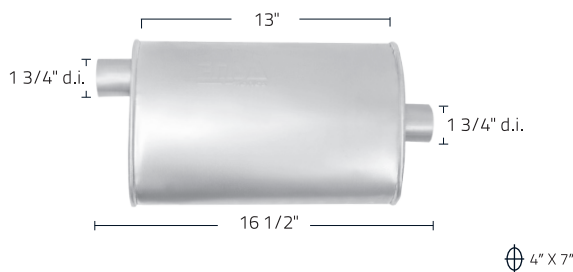

*d.i. diámetro interior *d.e. diámetro exterior

S-AL-713-LC

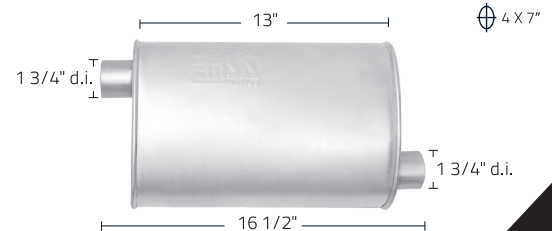

S-AL-713-LL

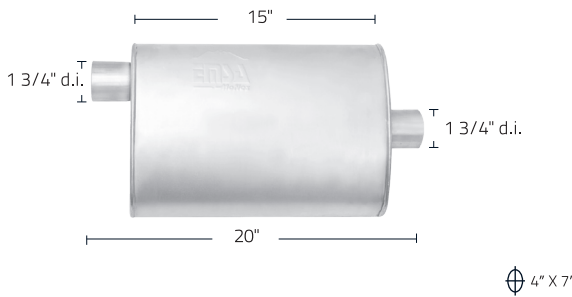
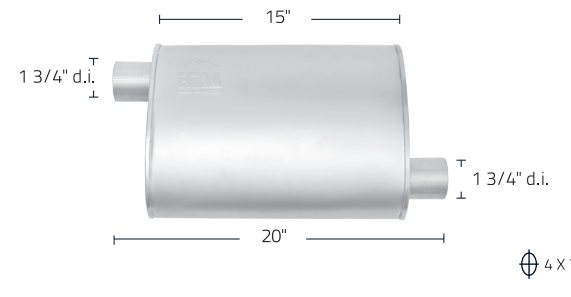
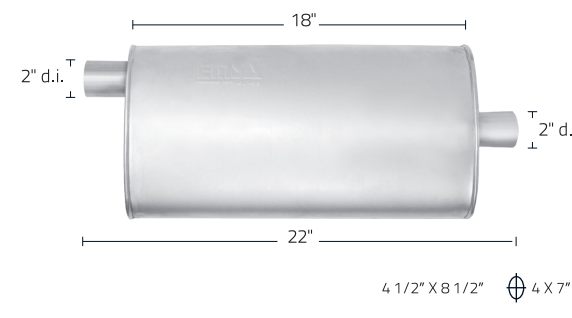
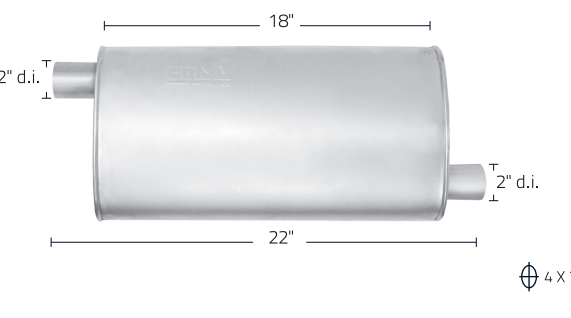
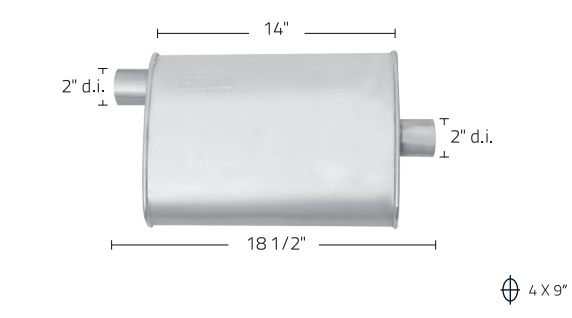
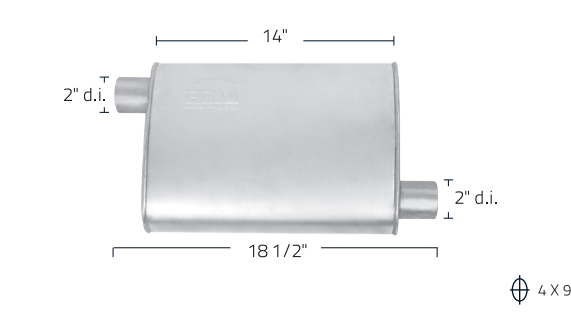
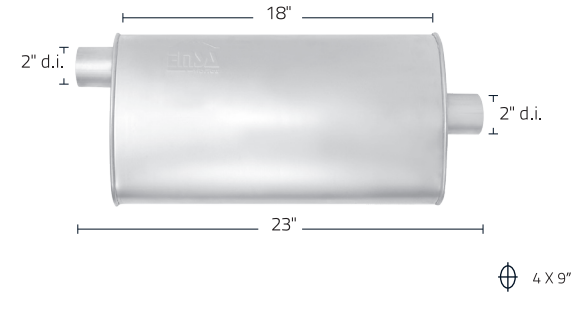

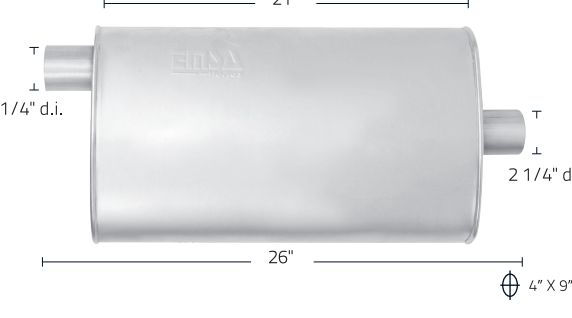
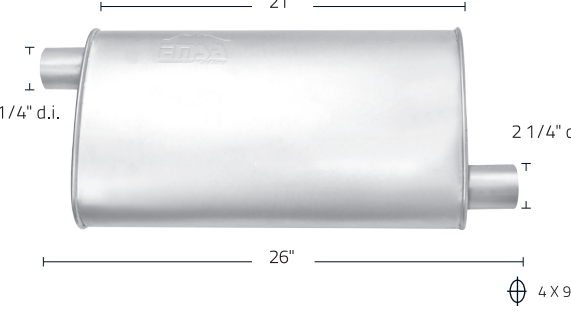
Modelo		Modelo	
S-AL-716-LC	 <p>15" (top length) 20" (bottom length) 1 3/4" d.i. (left inlet) 1 3/4" d.i. (right inlet) 4" X 7" (diameter)</p>	S-AL-716-LL	 <p>15" (top length) 20" (bottom length) 1 3/4" d.i. (left inlet) 1 3/4" d.i. (right inlet) 4" X 7" (diameter)</p>
S-AL-718-LC	 <p>18" (top length) 22" (bottom length) 2" d.i. (left inlet) 2" d.i. (right inlet) 4 1/2" X 8 1/2" (body size) 4" X 7" (diameter)</p>	S-AL-718-LL	 <p>18" (top length) 22" (bottom length) 2" d.i. (left inlet) 2" d.i. (right inlet) 4" X 7" (diameter)</p>
S-AL-915-LC	 <p>14" (top length) 18 1/2" (bottom length) 2" d.i. (left inlet) 2" d.i. (right inlet) 4" X 9" (diameter)</p>	S-AL-915-LL	 <p>14" (top length) 18 1/2" (bottom length) 2" d.i. (left inlet) 2" d.i. (right inlet) 4" X 9" (diameter)</p>
S-AL-918-LC	 <p>18" (top length) 23" (bottom length) 2" d.i. (left inlet) 2" d.i. (right inlet) 4" X 9" (diameter)</p>	S-AL-918-LL	 <p>18" (top length) 23" (bottom length) 2" d.i. (left inlet) 2" d.i. (right inlet) 4" X 9" (diameter)</p> <p>*d.i. diámetro interior *d.e. diámetro exterior</p>
S-AL-921-LC	 <p>21" (top length) 26" (bottom length) 2 1/4" d.i. (left inlet) 2 1/4" d.i. (right inlet) 4" X 9" (diameter)</p>	S-AL-921-LL	 <p>21" (top length) 26" (bottom length) 2 1/4" d.i. (left inlet) 2 1/4" d.i. (right inlet) 4" X 9" (diameter)</p>

Modelo	Modelo	Modelo	Modelo
SA-924 1X2		SA-924-LC	<p>*d.i. diámetro interior *d.e. diámetro exterior</p>
SA-ASTRA		SA-CAMARO	
SA-CAPTIVA		SA-CAPTIVA-1S	
SA-CAVAL 96-98		SA-CAV 96-98-ORG	
SA-CAVALIER		SA-CELEBRITY	



SILENCIADORES ORIGINALES EMSA

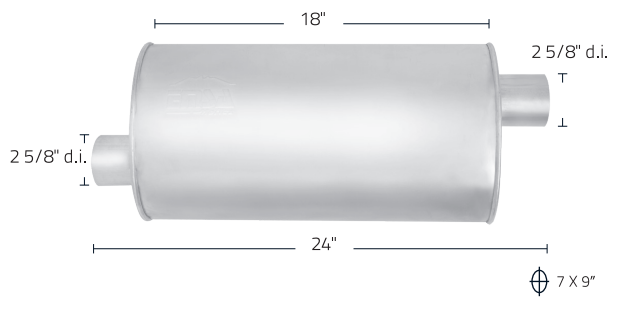
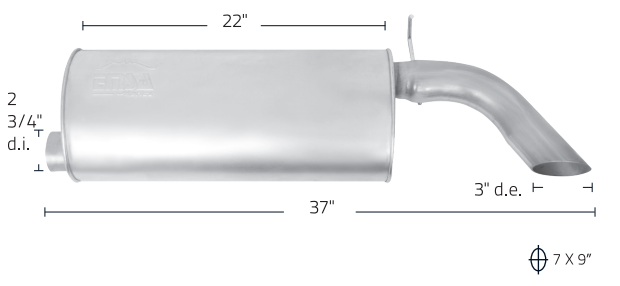
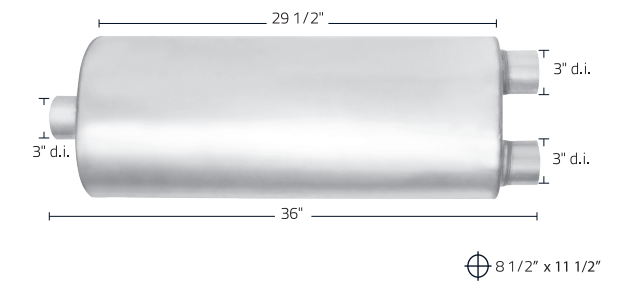
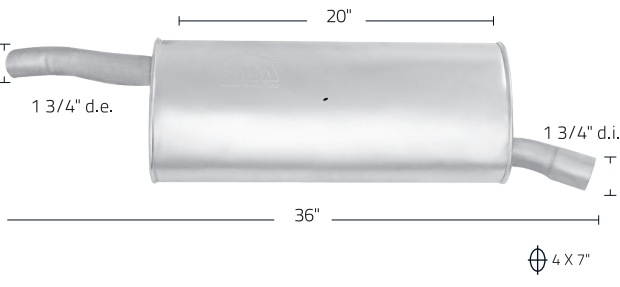
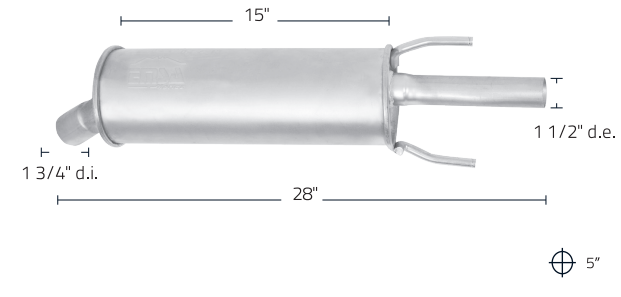
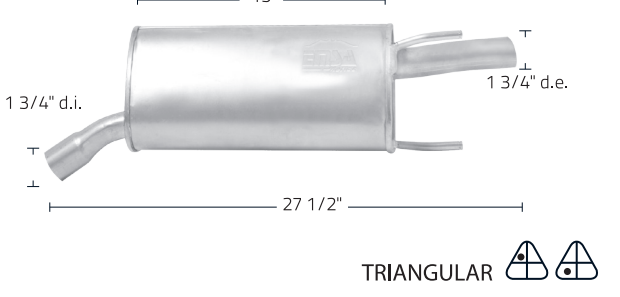
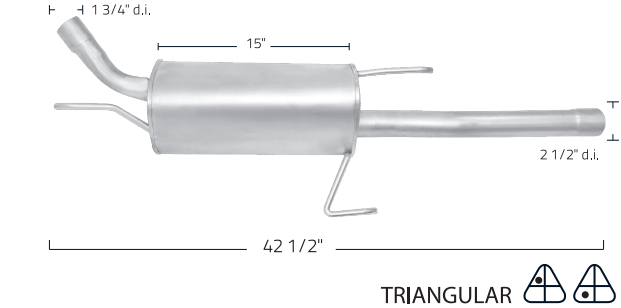
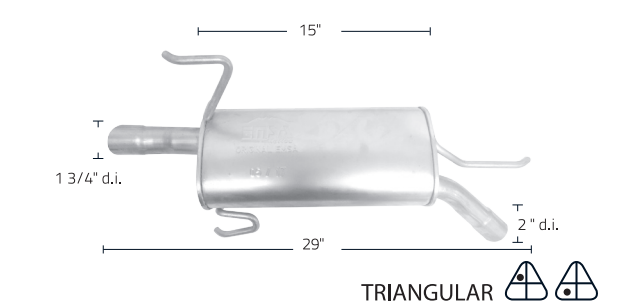
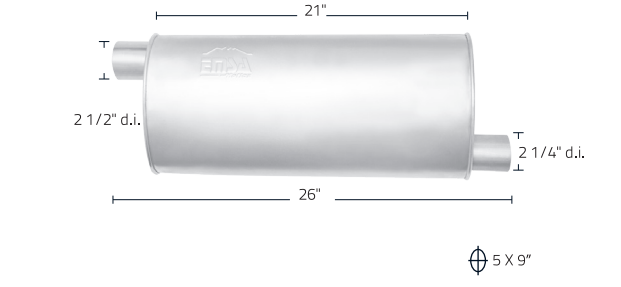
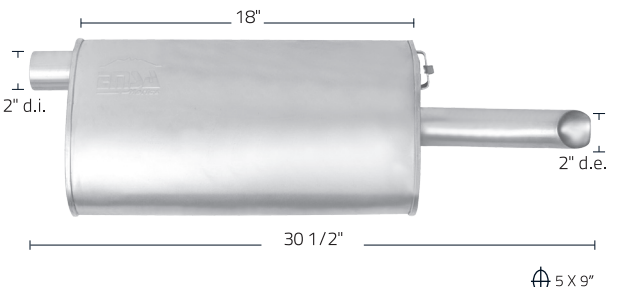

Modelo		Modelo	
SA-CHEV-2 R	 <p>18" (top length) 24" (bottom length) 2 5/8" d.i. (left inlet) 2 5/8" d.i. (right outlet) 7 X 9" (diameter)</p>	SA-CHEV-2R-ORIG.	 <p>22" (top length) 37" (bottom length) 2 3/4" d.i. (left inlet) 3" d.e. (right outlet) 7 X 9" (diameter)</p>
SA-CHEV-6T	 <p>29 1/2" (top length) 36" (bottom length) 3" d.i. (left inlet) 3" d.i. (right inlet) 3" d.i. (right outlet) 8 1/2" x 11 1/2" (diameter)</p>	SA-CHEVY-CTA	 <p>20" (top length) 36" (bottom length) 1 3/4" d.e. (left inlet) 1 3/4" d.i. (right outlet) 4 X 7" (diameter)</p>
SA-CHEVY-JOY-03	 <p>15" (top length) 28" (bottom length) 1 3/4" d.i. (left inlet) 1 1/2" d.e. (right outlet) 5" (diameter)</p>	SA-JOY-TRI	 <p>15" (top length) 27 1/2" (bottom length) 1 3/4" d.i. (left inlet) 1 3/4" d.e. (right outlet) TRIANGULAR</p>
SA-CORSA-03	 <p>15" (top length) 42 1/2" (bottom length) 1 3/4" d.i. (left inlet) 2 1/2" d.i. (right outlet) TRIANGULAR</p>	SA-CORSA-04	 <p>15" (top length) 29" (bottom length) 1 3/4" d.i. (left inlet) 2" d.i. (right outlet) TRIANGULAR</p>
SA-CHEYENNE	 <p>21" (top length) 26" (bottom length) 2 1/2" d.i. (left inlet) 2 1/4" d.i. (right outlet) 5 X 9" (diameter)</p>	SA-CUTLAS	 <p>18" (top length) 30 1/2" (bottom length) 2" d.i. (left inlet) 2" d.e. (right outlet) 5 X 9" (diameter)</p>



Modelo	Modelo	Modelo	Modelo
SA-CTA-PICK-UP		SA-LUV	<p>*d.i. diámetro interior *d.e. diámetro exterior</p>
SA-MALIBU-08-S		SA-MALIBU-08-2S	
SA-MALIBU-09		SA-MATIZ	
SA-MATIZ-06			
SA-MERIVA		SA-MONZA-03	





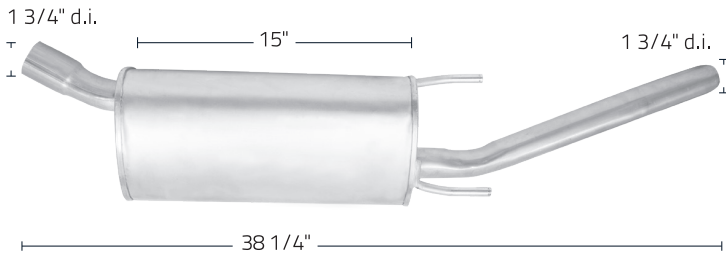

SILENCIADORES ORIGINALS EMSA

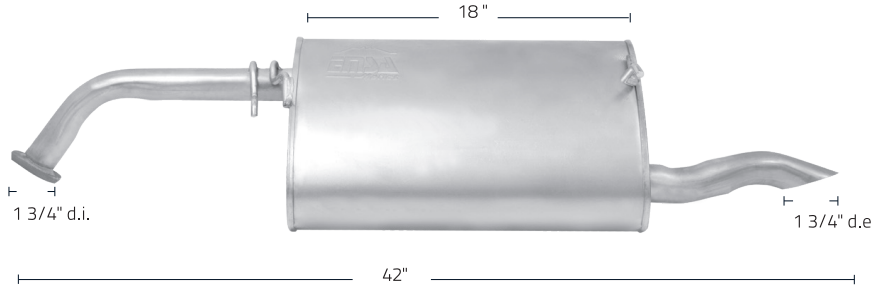
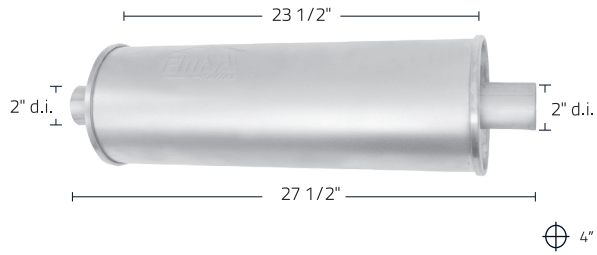
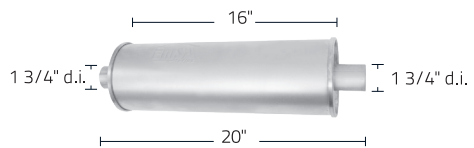
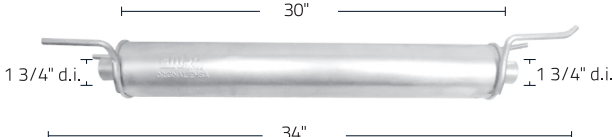
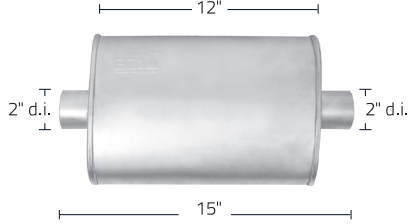
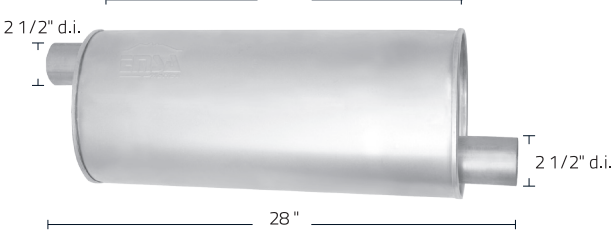
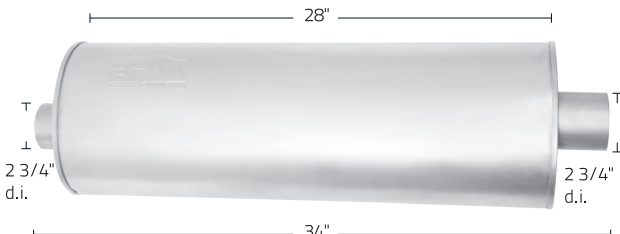

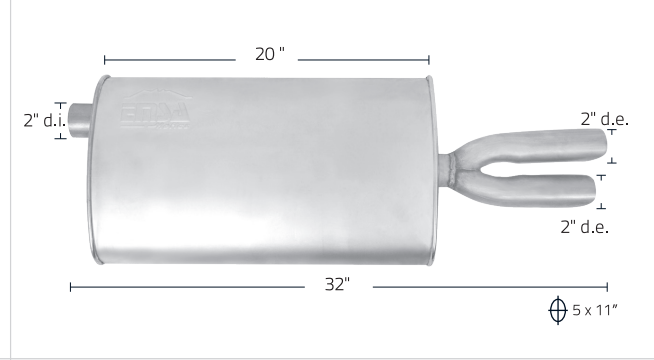
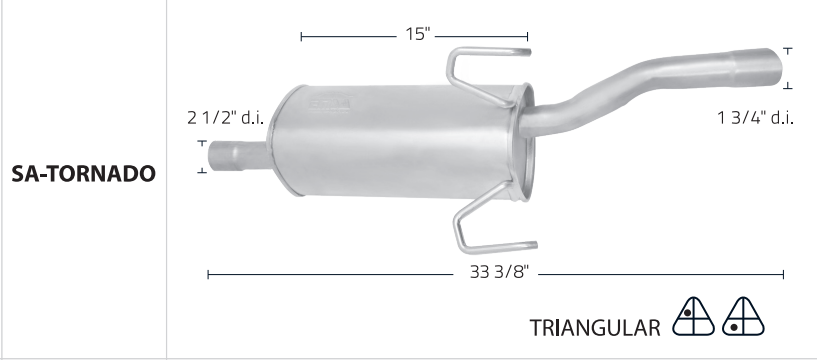

Modelo Modelo

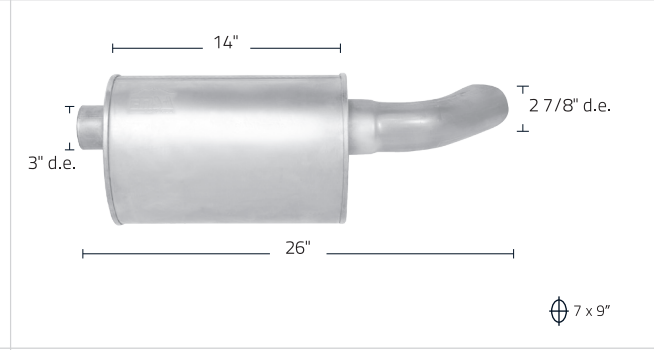
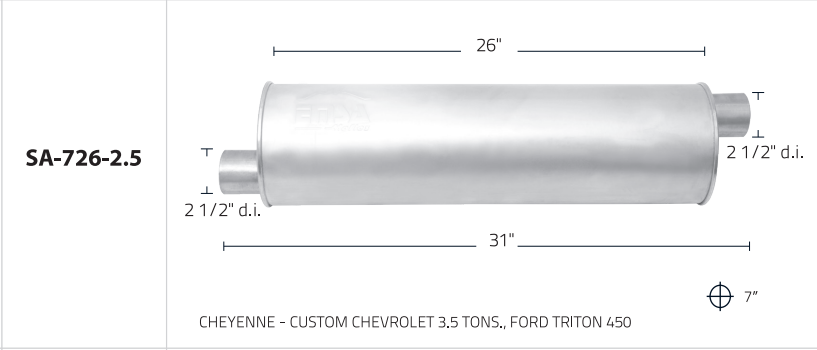
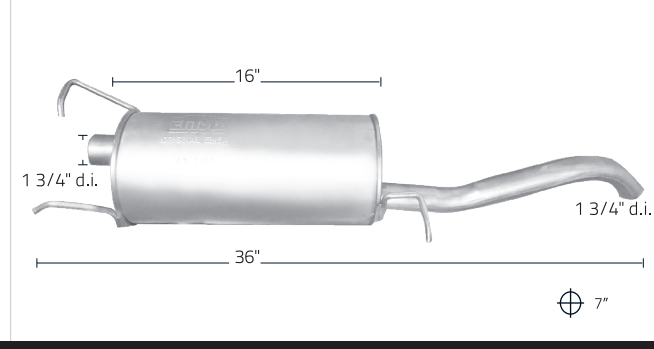
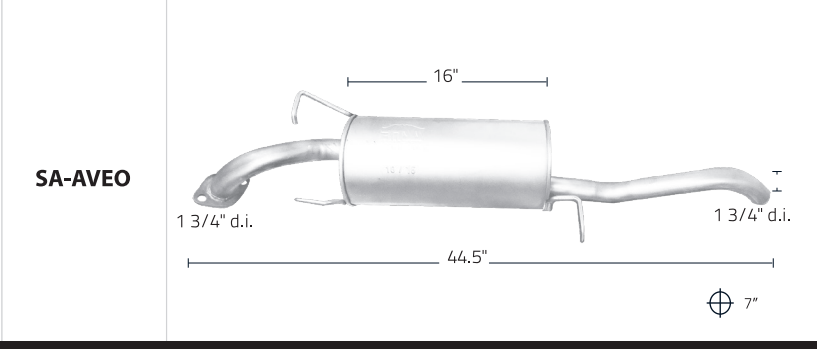
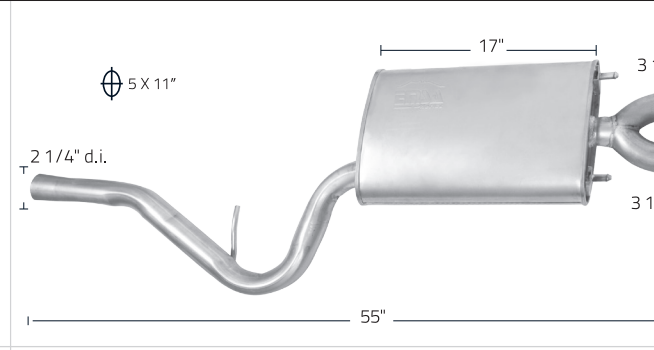
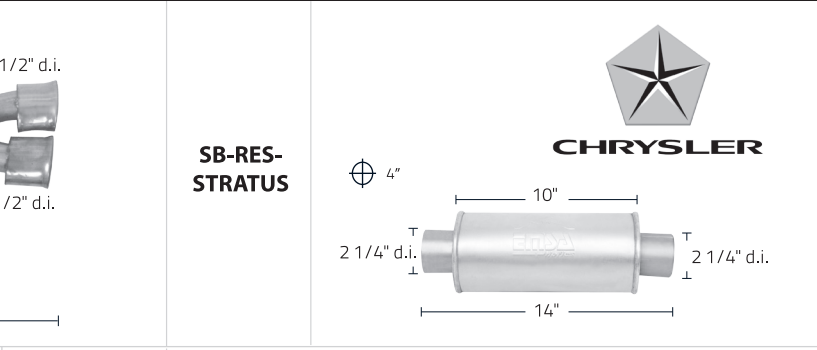
<p>SA-MONZATRI</p>		<p>TRIANGULAR  </p>	
<p>SA-OPTRA</p>		<p>\varnothing 5 x 11"</p>	
<p>SA-RESASTRA</p>	 <p>\varnothing 4"</p>	<p>SA-RES-CHEVY</p>	 <p>\varnothing 5"</p>
<p>SA-RES-CORSA</p>	 <p>\varnothing 4"</p>	<p>SA-RES-GM</p>	 <p>\varnothing 4 x 7"</p>
<p>SA-SILVERADO</p>	 <p>\varnothing 7 x 9"</p>	<p>SA-SUBURBAN</p>	 <p>\varnothing 7 x 9"</p>

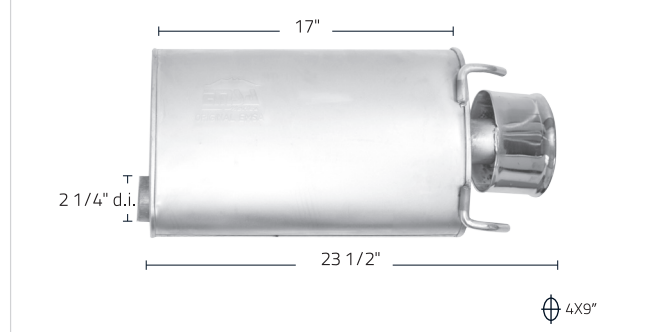
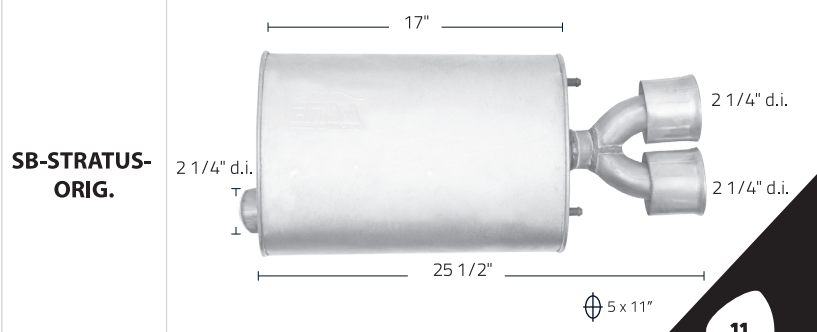
Cuerpo galvanneal cal. 22 • Forro aluminizado cal. 26 • Interiores en galvanneal cal. 22 • tapa aluminizada cal. 18 • Boquilla aluminizada cal. 18

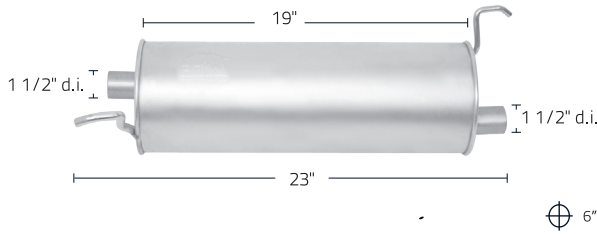
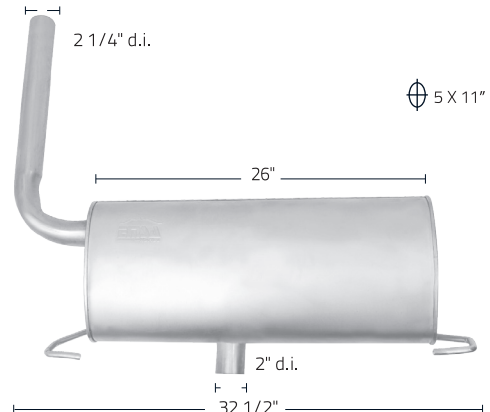
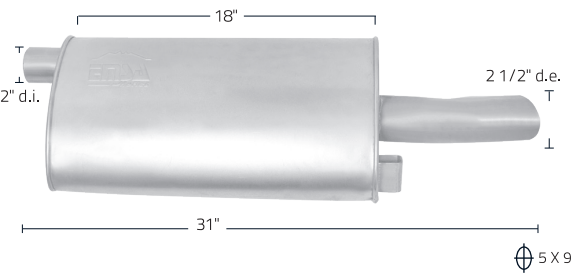
Modelo	Modelo	Modelo
<p>SA-SUNFIRE</p> 	<p>SA-TORNADO</p>  <p>TRIANGULAR </p>	
<p>SA-TRAIL-BLAZER</p> 	<p>SA-726-2.5</p>  <p>CHEYENNE - CUSTOM CHEVROLET 3.5 TONS., FORD TRITON 450</p>	
<p>SA-AVEO-SE</p> 	<p>SA-AVEO</p> 	
<p>SB-STRATUS/ENS.</p> 	<p>SB-RES-STRATUS</p>  <p> CHRYSLER</p>	
<p>SB-STRATUS-ECO</p> 	<p>SB-STRATUS-ORIG.</p> 	

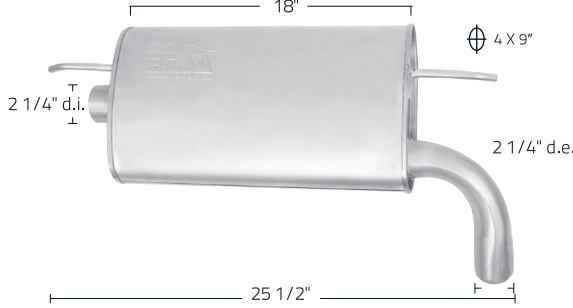
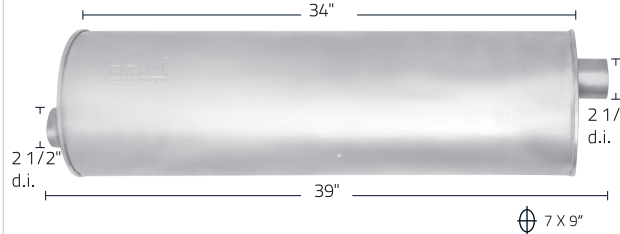
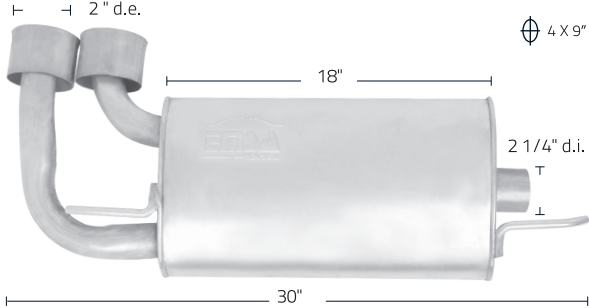
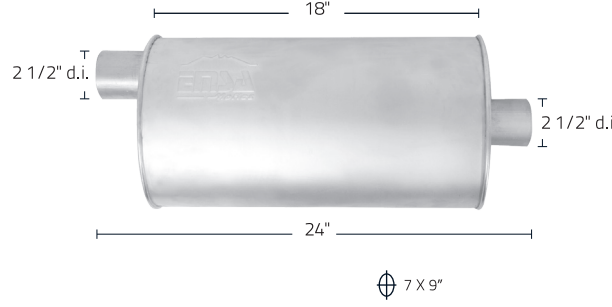
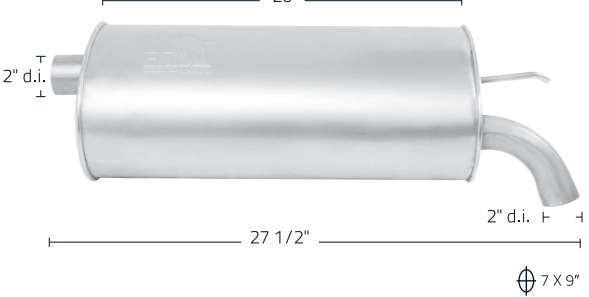
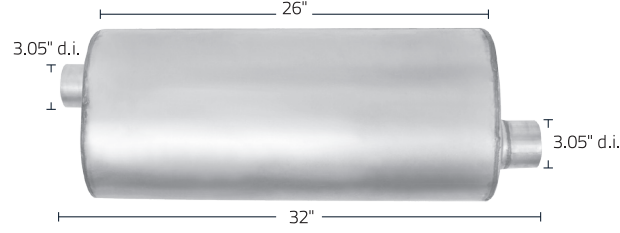
Modelo		Modelo	
SB-ATOS	 <p>*d.i. diámetro interior *d.e. diámetro exterior</p>	SB-AVENGER	
SB-DART K		SB-PATRIOT	
SB-NEON		SB-RAM-7X9-97	
SB-NEON-2S		SB-RAM-7X9	
SB-NEON-02		SB-RAM-4000-05	 <p>*tipo equipo pesado, incluye caja</p>

Modelo	Modelo	Modelo	Modelo
SB-SHADOW		SB-SPIRIT	
SC-ECO SPORT		SC-EXPLORER-99	
SC-FIESTA			
SC-FIESTA-04		SC-FIESTA- IKON	
SC-FIESTA- 05			



Cuerpo galvanneal cal. 22 • Forro aluminizado cal. 26 • Interiores en galvanneal cal. 22 • Tapa aluminizada cal. 18 • Boquilla aluminizada cal. 18



SILENCIADORES ORIGINALES EMSA

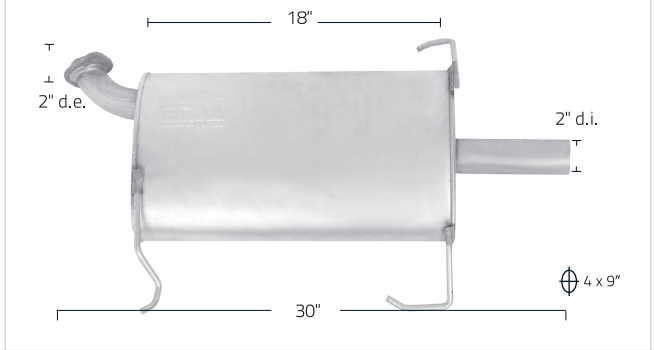
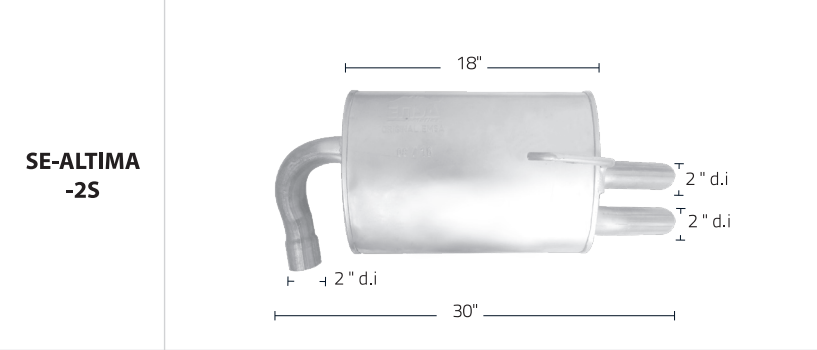
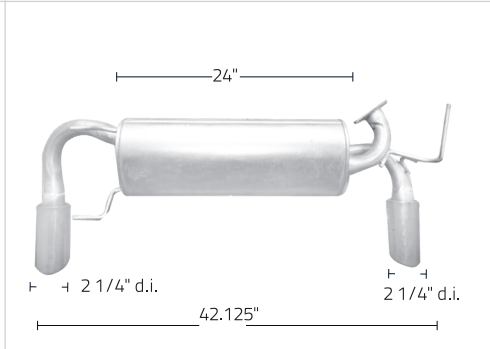

Modelo		Modelo	
SC-726	<p>25" 30" 2 1/4" d.i. 2" d.i. 2" d.i. 7"</p>	SC-COURIER	<p>17" 30" 1 3/4" d.i. 1 3/4" d.e. 5 X 11"</p>
SC-FOCUS-02	<p>9 1/2" 19" 2" d.i. 2" d.i. 5 X 11"</p>	SC-FORD-2R FI	<p>28" 33" 2" d.i. 2" d.i. 5 X 9"</p>
SC-FORD-K	<p>14 1/2" 23" 2" d.i. 2" d.i. 7"</p> <p>*d.i. diámetro interior *d.e. diámetro exterior</p>	SC-LOBO	<p>26" 31" 2 1/2" d.i. 2 1/2" d.i. 7 X 9"</p>
SC-MYSTIQUE	<p>12" 21" 1 3/4" d.i. 1 3/4" d.e. 4 X 9"</p> <p>*d.i. diámetro interior *d.e. diámetro exterior</p>	SC-RES-FIESTA-03	<p>9.5" 13.5" 1 3/4" d.i. 1 3/4" d.i.</p>
SC-RES-IKON	<p>10" 13" 2" d.i. 2" d.i. 6"</p>	SC-TEMPO	<p>18" 28 1/2" 2" d.i. 1 3/4" d.e. 7"</p>

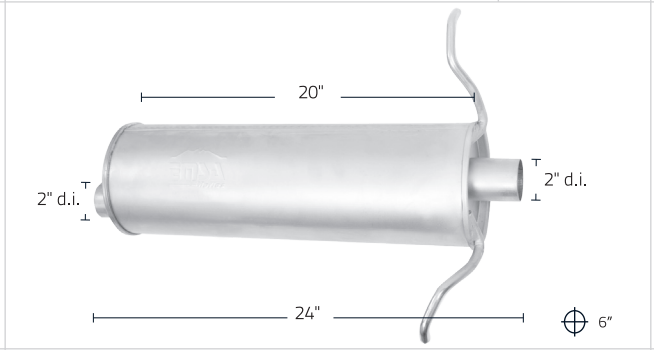
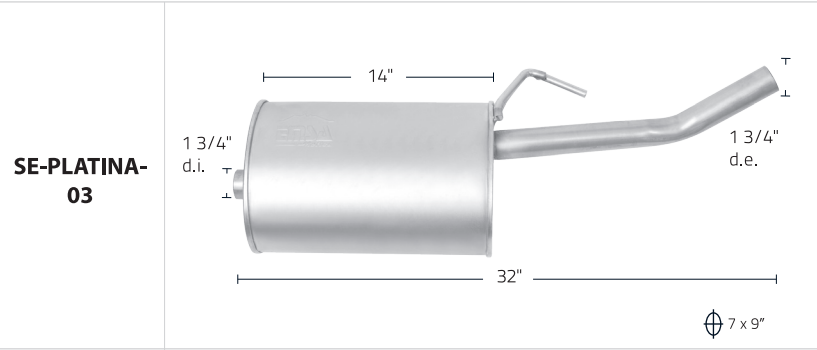
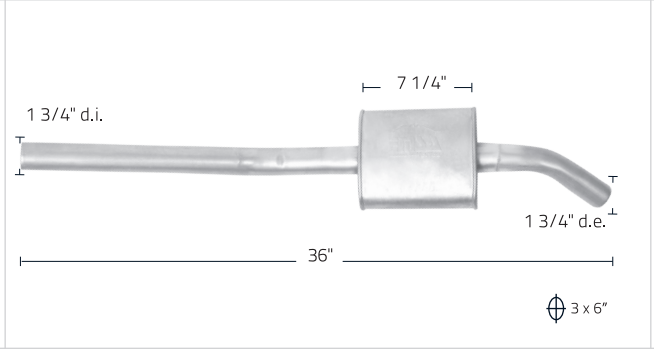
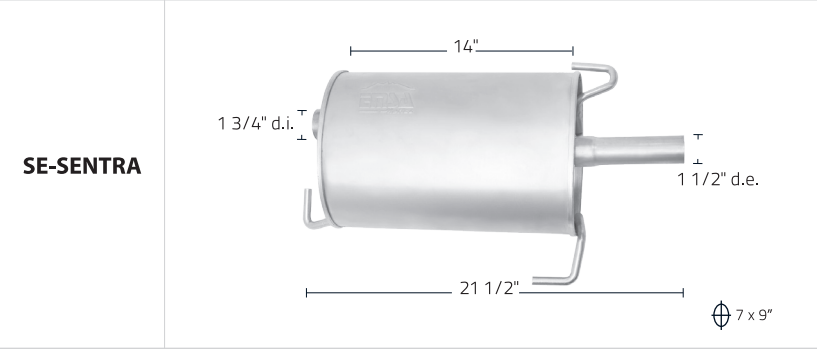
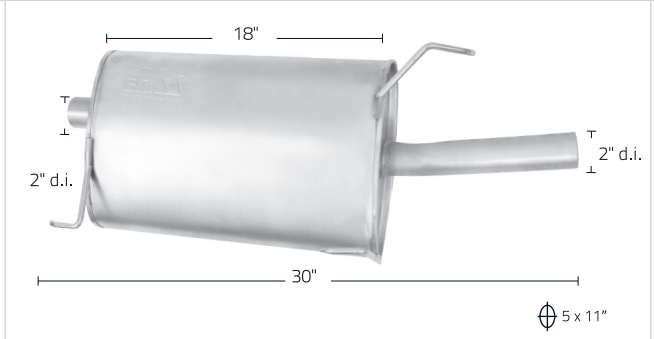
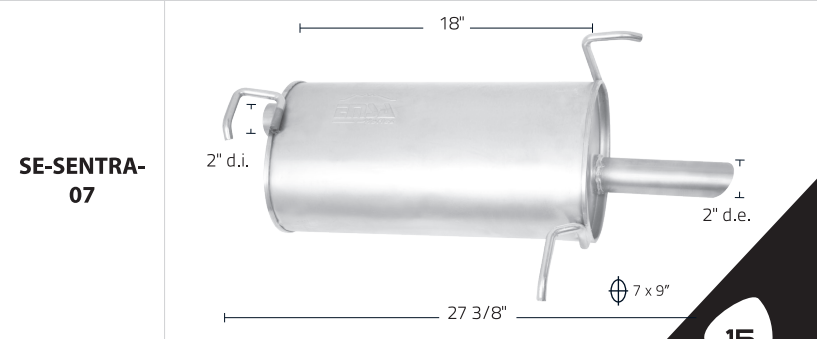
Modelo	Modelo	Modelo
<p>SE-ALTIMA</p> 		<p>SE-ALTIMA -2S</p> 
<p>SE-MURANO</p> 	<p>SE-NISSAN 613</p> 	
<p>SE-NISSAN 96-99</p> 		<p>SE-PLATINA- 03</p> 
<p>SE-RES- NISSAN</p> 		<p>SE-SENTRA</p> 
<p>SE-SENTRA- 03</p> 		<p>SE-SENTRA- 07</p> 

Modelo		Modelo	
SE-TIDA		SE-TSU-I	
SE-TSU-II		SE-TSU-III	
SE-URBAN		SE-3607-CC	
SE-X-TRAIL-ORG		SE-3612-CC	
		SE-418	<p>*d.i. diámetro interior *d.e. diámetro exterior</p>

Modelo

Modelo

SE-418-ENS

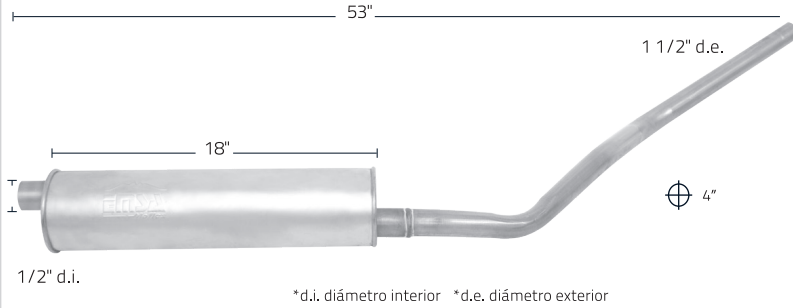

SF-PEUGEOT-02

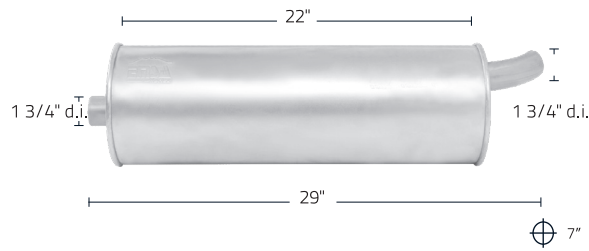

SF-PEUGEOT-03

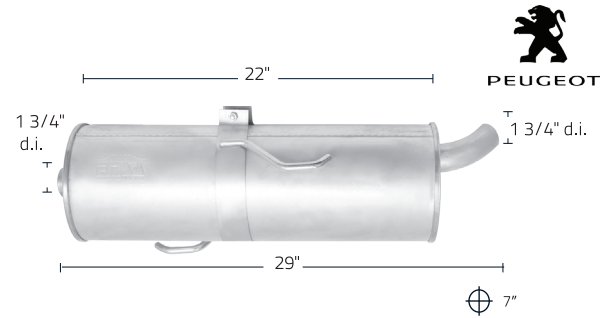

SG-POINTER 01-03

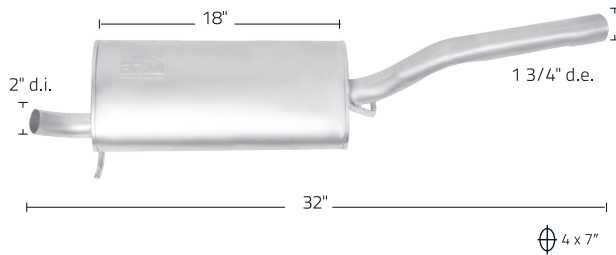

SG-POINTER

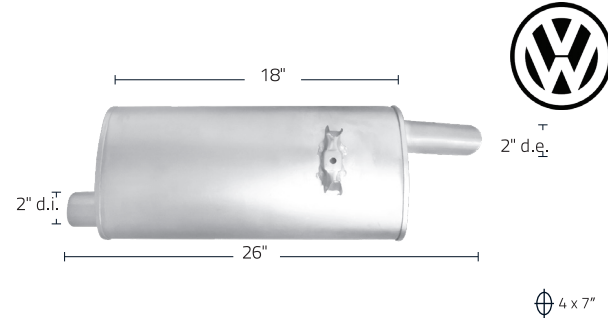

SG-CARIBE

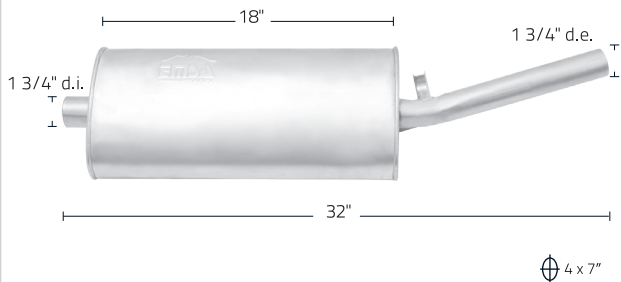

SG-COMBI

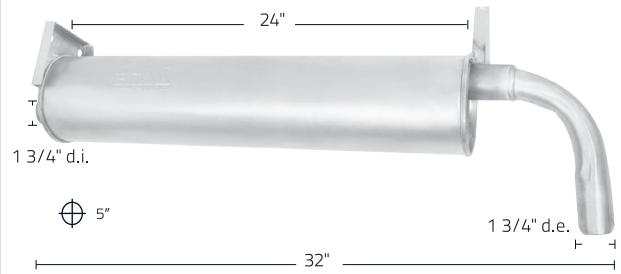

SG-DERBY

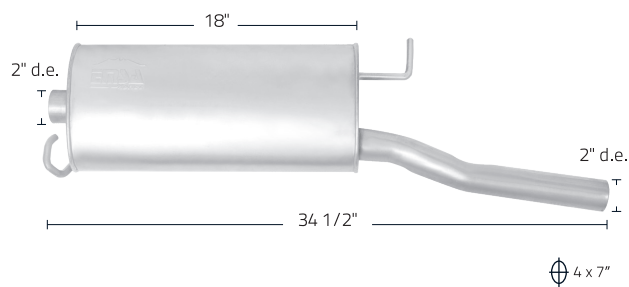

SG-DERBY-00-02

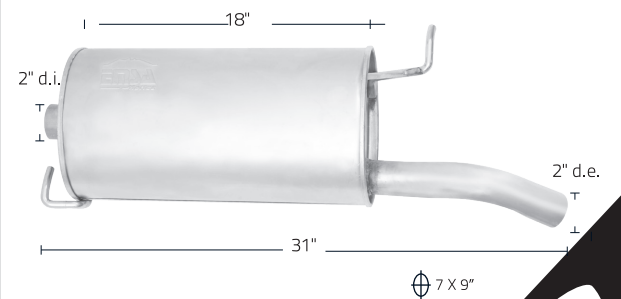



SILENCIADORES ORIGINALES EMSA



Modelo

Modelo

SG-GOLF
GTI

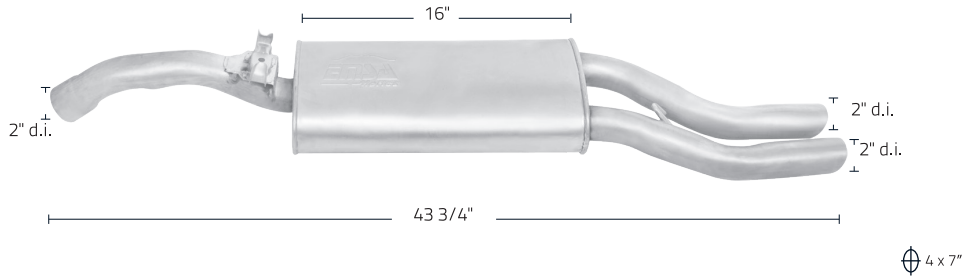

SG-JETTA

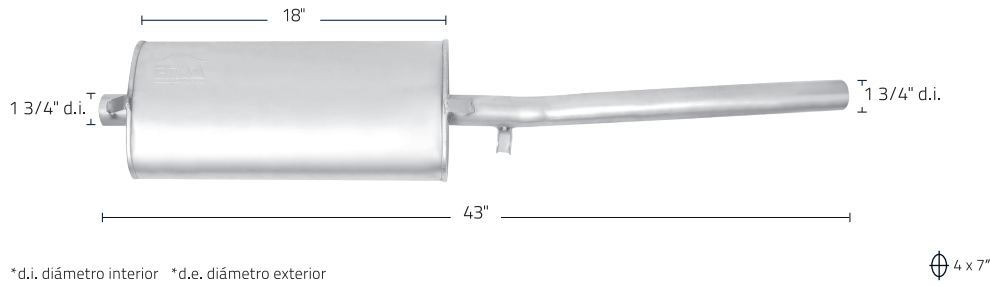

SG-JETTA-
G4

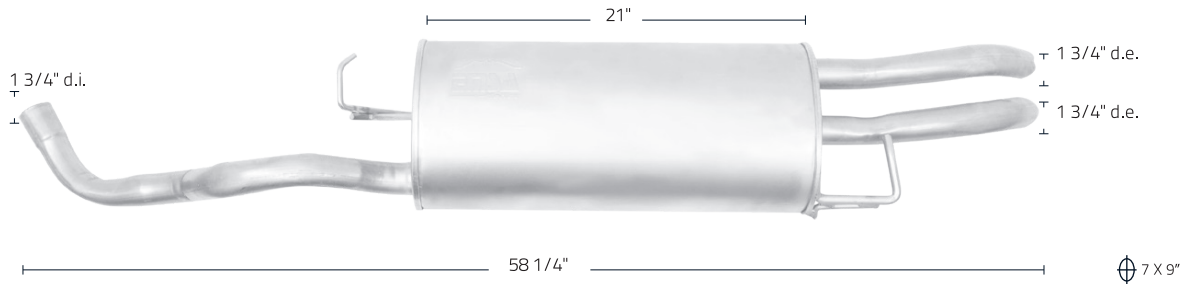

SG-JETTA-
GL

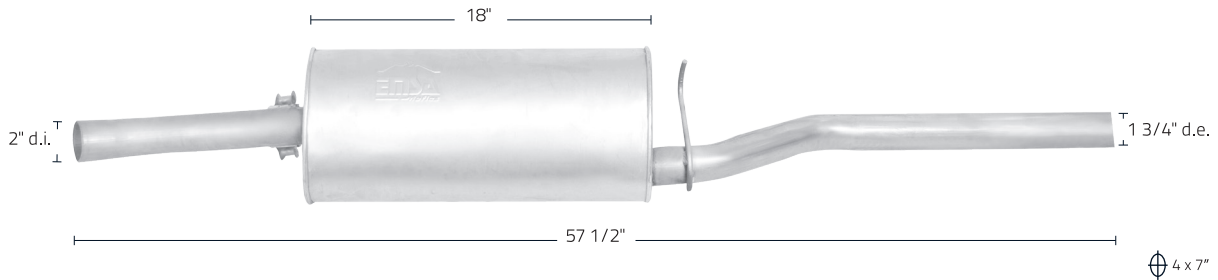

SG-JETTA-
GLS

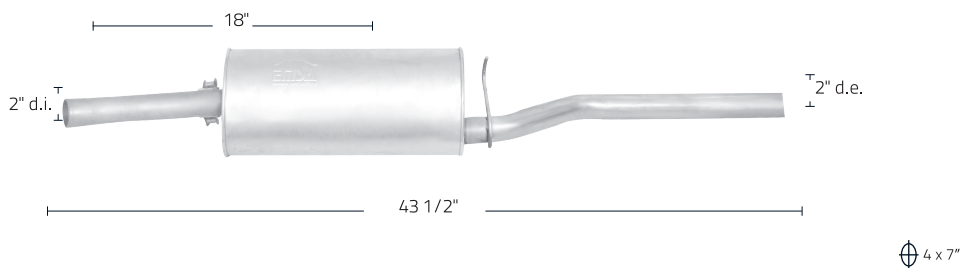

Modelo	Modelo	Modelo
<p>SG-VW-C</p>	<p>13 1/2" 1 3/4" d.i. 1 3/4" d.e. ⊕ 5"</p>	<p>SG-RES-GOLF</p> <p>18" 2" d.i. 2" d.i. 32" ⊕ 4 x 7"</p>
<p>SG-VW</p>	<p>21" 1 3/4" d.i. 1 3/4" d.e. 22 1/2" ⊕ 5"</p>	<p>SG-RES-JETTA</p> <p>12" 2" d.i. 2" d.e. 30 3/4" ⊕ 4 x 7"</p>
<p>SG-GOLF</p>	<p>18" 1 3/4" d.i. 1 3/4" d.e. 32 1/2" ⊕ 4 x 7"</p> <p>*d.i. diámetro interior *d.e. diámetro exterior</p>	<p>SG-GOLF-CL</p> <p>18" 2" d.i. 2" d.e. 28" ⊕ 4 x 7"</p>
<p>SG-RES-G-J</p>	<p>18" 2" d.e. 2" d.i. 27 1/2" ⊕ 4 x 7"</p>	
<p>SG-GOLF GL</p>	<p>16" 2" d.i. 2 1/2" d.i. 43 3/4" ⊕ 4 x 7"</p>	

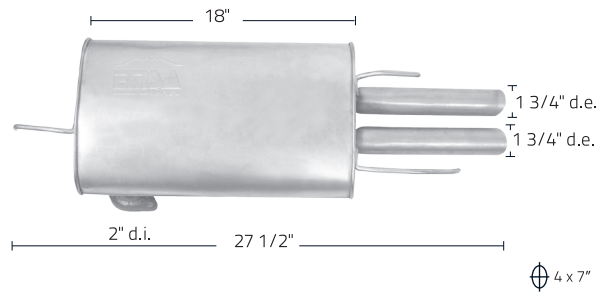
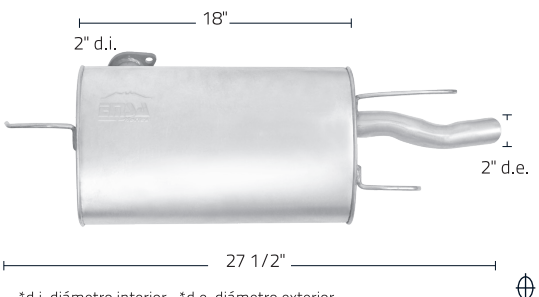
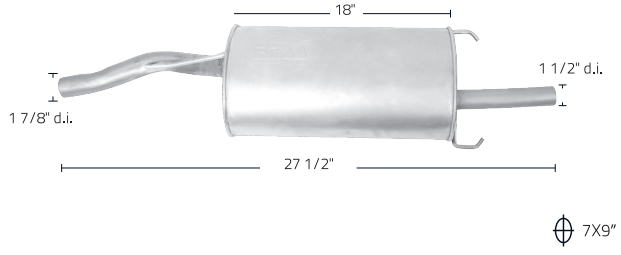
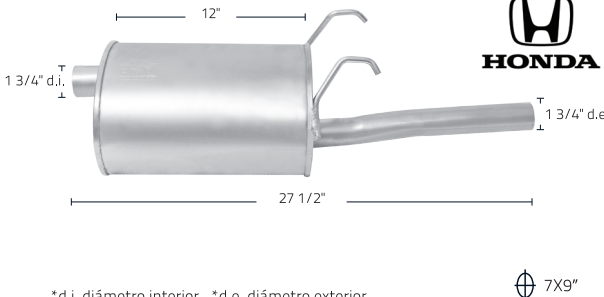
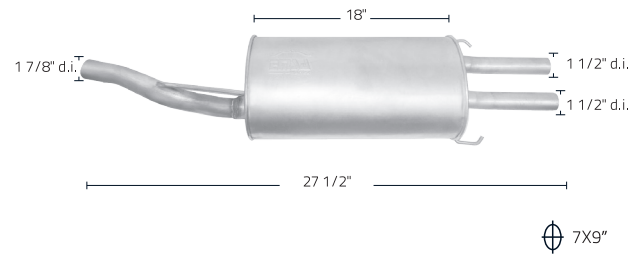
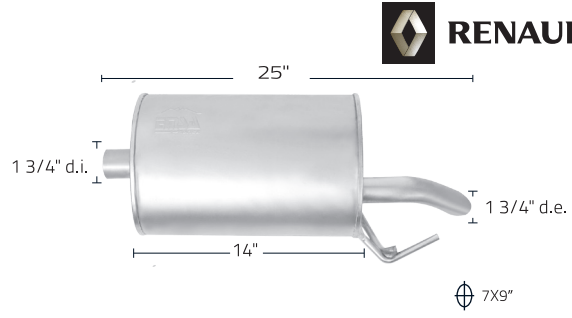
Modelo	Modelo	Modelo
ST-CAMRY- LEXUS-92-93	 <p>18" 27 1/2" 2" d.i. 1 3/4" d.e. 1 3/4" d.e. ⌀ 4 x 7"</p>	ST-CAMRY- 92-96  <p>18" 27 1/2" 2" d.i. 2" d.e. *d.i. diámetro interior *d.e. diámetro exterior ⌀ 5 x 11"</p>
SH- ACCORD- 96-97	 <p>18" 27 1/2" 1 7/8" d.i. 1 1/2" d.i. ⌀ 7x9"</p>	SH-HONDA- CIVIC-97-01  <p>12" 27 1/2" 1 3/4" d.i. 1 3/4" d.e. *d.i. diámetro interior *d.e. diámetro exterior ⌀ 7x9"</p>
SH- ACCORD- 96	 <p>18" 27 1/2" 1 7/8" d.i. 1 1/2" d.i. 1 1/2" d.i. ⌀ 7x9"</p>	SR-CLIO  <p>25" 14" 1 3/4" d.i. 1 3/4" d.e. ⌀ 7x9"</p>



LO MAS NUEVO

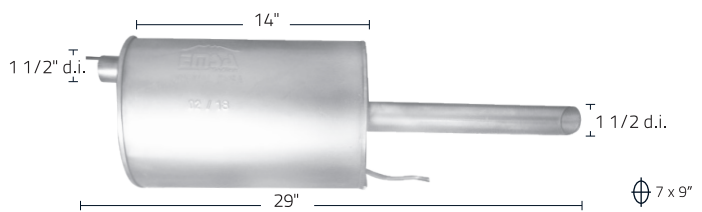
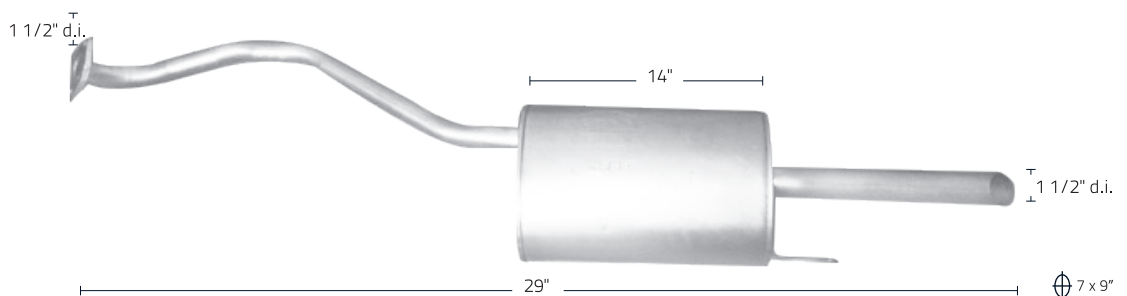

SE-VERSA 2016	 <p>14" 29" 1 1/2" d.i. 1 1/2" d.i. ⌀ 7 x 9"</p>
SE-VERSA 2016-E	 <p>14" 29" 1 1/2" d.i. 1 1/2" d.i. ⌀ 7 x 9"</p>



Sonido deportivo muy agradable • Mayor desarrollo de su máquina • Menor consumo de combustible

AIR FLOW-1
AF-1

AF-1 4"x9" CROSS SECTION 6.5" LARGO DE CUERPO 12.5" LARGO TOTAL



SD-LL-6.5
entrada/salida 2 ¼"



SD-LC-6.5
entrada/salida 2 ¼"



SD-CC-6.5
entrada/salida 2 ¼"

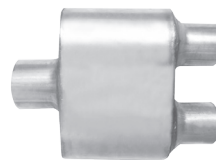

SD-1X2-6.5
entrada 2 ½"
salidas 2 ¼"-2 ¼"

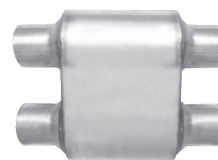

SD-2X2-6.5
entrada 2 ¼"
salidas 2 ¼"-2 ¼"

AF-1 4"x9" CROSS SECTION 13" LARGO DE CUERPO 19" LARGO TOTAL



SD-LL-13
entrada/salida 2 ¼"



SD-LC-13
entrada/salida 2 ¼"



SD-1X2-13
entrada 3"
salida 2 ½"-2 ½"

AF-1 XL 4"x9" CROSS SECTION 17" LARGO DE CUERPO 23" LARGO TOTAL



SD-1X2-17
entrada 3"
salida 2 ½"-2 ½"



SD-2X2-17
entrada 2 ¼"-2 ¼"
salida 2 ¼"-2 ¼"



SD-2X1-17
entrada 2 ¼"-2 ¼"
salida 3"



SD-LL-17
entrada 2 ¼"
salida 2 ¼"-2 ¼"



SD-LC-17
entrada 2 ½"
salida 2 ½"



SD-CAMARO
entrada 2 ½"
salida 2 ½"-2 ½"

AF-R 5" REDONDO 13" LARGO DE CUERPO 18" LARGO TOTAL



SD-R-2
entrada 2" / salida 2"



SD-R-2 ¼"
entrada 2 ¼" / salida 2 ¼"



SD-R-2 ½"
entrada 2 ½" / salida 2 ½"



SD-R-3"
entrada 3" / salida 3"



ALTO RENDIMIENTO

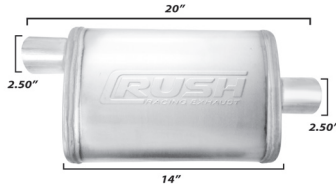

R-SC212

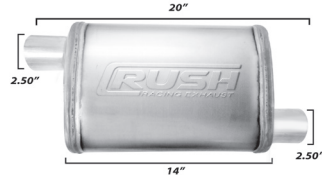

R-SS212

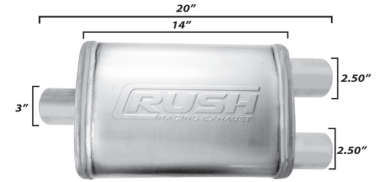

R-SD30212

MUFFLER STAINLESS STEEL 409
MOFLES DE ACERO INOXIDABLE 409
SILICON FIBER HIGH RESISTANCE
FIBRA DE SILICON ALTA RESISTENCIA
HIGH QUALITY
ALTA CALIDAD

PERFORMANCE
DESEMPEÑO
RACING SOUND
SONIDO DEPORTIVO



MOFLES CON COLILLA



R-108A

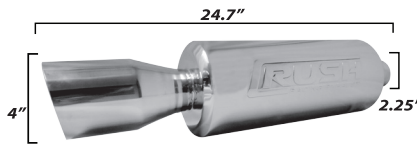

R-111



R-114

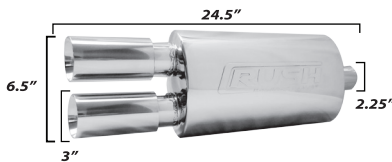

R-117



R-119

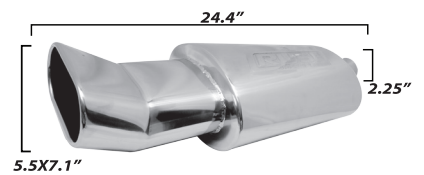

R-124

MUFFLER STAINLESS STEEL 304
MOFLES DE ACERO INOXIDABLE 409
SILICON FIBER HIGH RESISTANCE
FIBRA DE SILICON ALTA RESISTENCIA
HIGH QUALITY
ALTA CALIDAD
PERFORMANCE
DESEMPEÑO
RACING SOUND
SONIDO DEPORTIVO



R-201



R-305



REPUESTO
FORD TRACTOR

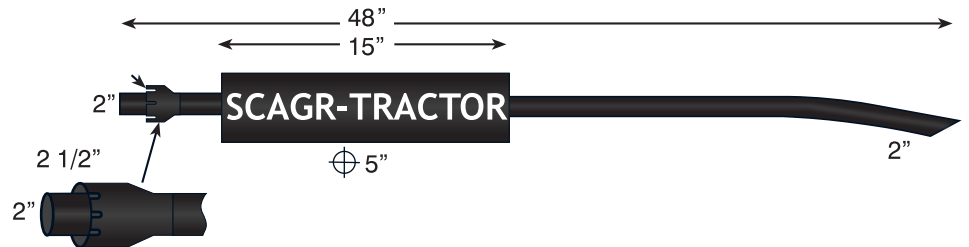

JOHN DEERE
REPUESTOS
JOHN DEERE TRACTOR

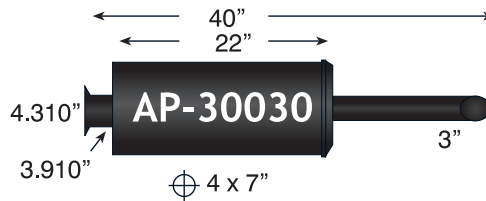
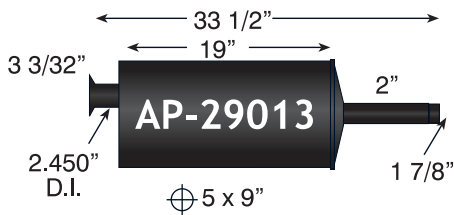
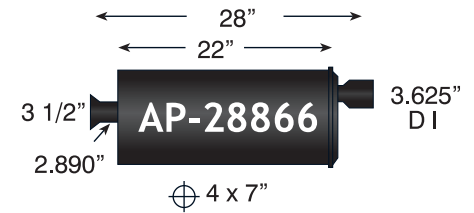
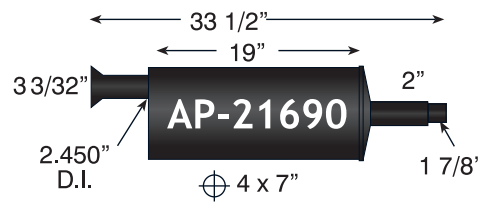

MASSEY FERGUSON
REPUESTO
MASSEY FERGUSON TRACTOR

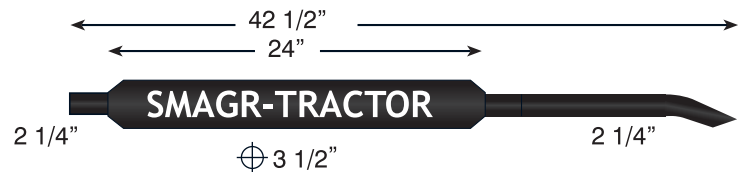

NEW HOLLAND
REPUESTO
NEW HOLLAND TRACTOR

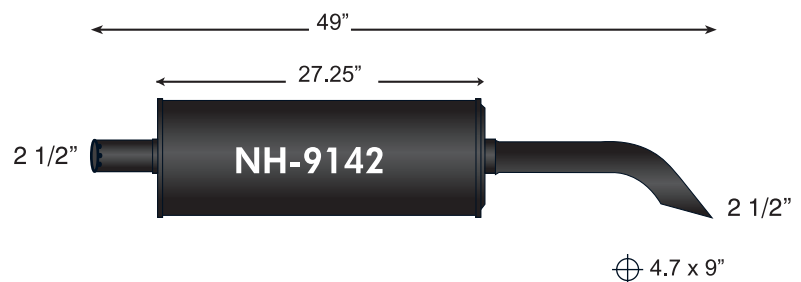



SP-007-001
KERKER GRANDE



SP-007-002
KERKER CHICO



SP-007-007
GRANADA GRANDE

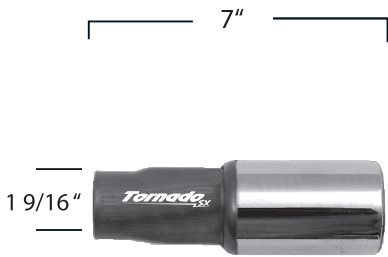

SP-007-008
GRANADA CHICA



SP-007-009
HEADER



SP-007-013
CAÑÓN



SP-007-014
SILENCIADOR V.W. ECONOMICO
2 SALIDAS



SP-007-015
SILENCIADOR V.W. ECONOMICO
1 SALIDA



SP-TRUSH-18"X32"
TRUSH

EMSA OBD I

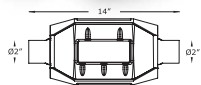

C-E-6904-B251

OVALADO, LARGO TOTAL 14"
BOQ. 2"

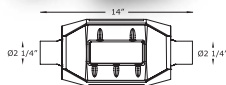
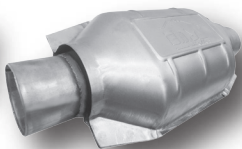

C-E-6905-B251

OVALADO, LARGO TOTAL 14"
BOQ. 2 1/4"

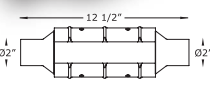

C-E-6904-D232

REDONDO, LARGO TOTAL 12 1/2",
BOQ. 2"

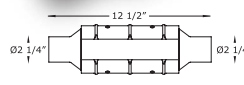
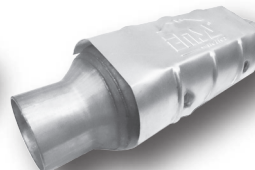

C-E-6905-D232

REDONDO, LARGO TOTAL 12 1/2",
BOQ. 2 1/4"

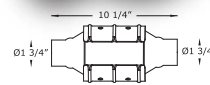
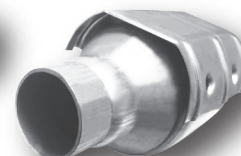

C-E-SMALL

REDONDO, LARGO TOTAL 10 1/4",
BOQ. 1 3/4"

EMSA OBD II

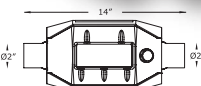

C-E-2504-B151

OVALADO CON SENSOR,
LARGO TOTAL 14", BOQ. 2"

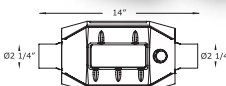

C-E-2505-B151

OVALADO CON SENSOR,
LARGO TOTAL 14", BOQ. 2 1/4"

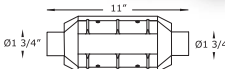
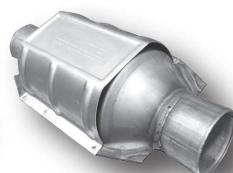

C-E-2503-E221/ 2504-E221

REDONDO, LARGO TOTAL 11",
BOQ. 1 3/4", 2"

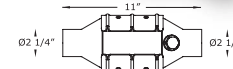
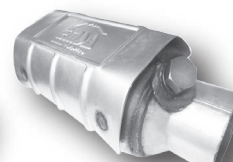

C-E-SMALL II

REDONDO CON SENSOR,
LARGO TOTAL 11", BOQ. 2 1/4"

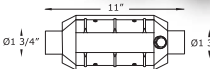
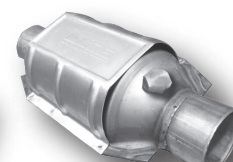

C-E-2503-E421/ 2504-E421

REDONDO CON SENSOR,
LARGO TOTAL 11" BOQ. 1 3/4", 2"

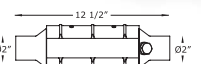

C-E-2504-D432

REDONDO CON SENSOR,
LARGO TOTAL 12 1/2", BOQ. 2"

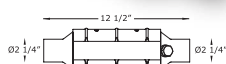

C-E-2505-D432

REDONDO CON SENSOR,
LARGO TOTAL 12 1/2", BOQ. 2 1/4"

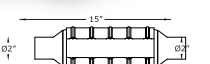

C-E-2504/05-D362

REDONDO, LARGO TOTAL 15",
BOQ. 2", 2 1/4" Y 2 1/2"

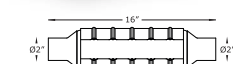

C-E-2504/05-D372

REDONDO, LARGO TOTAL 16",
BOQ. 2", 2 1/4" Y 2 1/2"



C-E-2504/05-D382

REDONDO, LARGO TOTAL 19",
BOQ. 2", 2 1/4" Y 2 1/2"

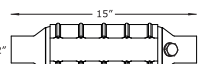

C-E-2504/05/06-D462

REDONDO, LARGO TOTAL 15",
BOQ. 2", 2 1/4" Y 2 1/2"

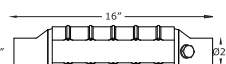

C-E-2504/05/06-D472

REDONDO, LARGO TOTAL 16",
BOQ. 2", 2 1/4" Y 2 1/2"



C-E-2504/05/06-D482

REDONDO, LARGO TOTAL 19",
BOQ. 2", 2 1/4" Y 2 1/2"

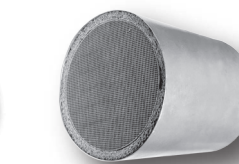

C-E-TSURU III

CARTUCHO OBDII NISSAN TSURU
2004 EN ADELANTE

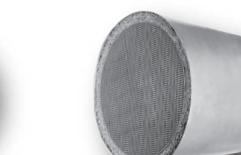

C-E-I-CARTUCHO-5"

APLICA PARA NISSAN ALTIMA, VOLKSWAGEN GOL
Y SAVEIRO, CHEVROLET TORNAO, HONDA PILOT,
HYUNDAI/DODGE ATOS

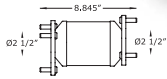

C-E-AVEO

APLICA PARA CHEVROLET AVEO

NOMENCLATURA EMSA (ULTIMOS 4 DÍGITOS)				
FAMILIA	TIPO	SENSOR	LARGO TOTAL	MATERIAL
C-I Catalizador importación	A OVALADO CATCO	1 CON SENSOR	1 10"	1 INOXIDABLE
C-E Catalizador emsa	B OVALADO EMSA	2 SIN SENSOR	2 11"	2 ALUMINIZADO
	C REDONDO CATCO	3 SENSOR AL CENTRO	3 12"	
	D REDONDO EMSA	4 SENSOR AL LADO	4 13"	
	E REDONDO EMSA CONCHA		5 14"	
				6 15"
			7 16"	
			8 19"	

*NOTA: Aplica solo catalizadores EMSA

EJEMPLO SERIE BOQUILLAS

C-E-2504-D362 = Serie 04 Boq. 2" C-E-2505-D362 = Serie 05 Boq. 2 1/4"

CATCO OBD I

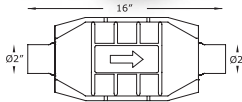

C-I-6574/75/76/77

OVALADO, LARGO TOTAL DE 16" BOQ. 2", 2 1/4", 2 1/2", 3"

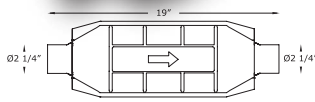

C-I-6595/96

OVALADO, LARGO TOTAL DE 19 1/2" BOQ. 2 1/4", 2 1/2"

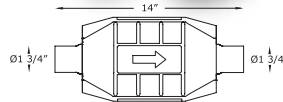

C-I-6903/04/05/06/07

OVALADO, LARGO TOTAL DE 14" BOQ. 1 3/4", 2", 2 1/4", 2 1/2", 3"

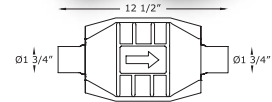

C-I-6903R/04R/05R/06R

REDONDO, LARGO TOTAL DE 12 1/2" BOQ. 1 3/4", 2", 2 1/4", 2 1/2".

CATCO OBD II

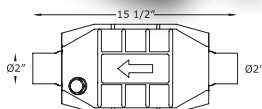

C-I-2504/05/06

OVALADO, LARGO TOTAL DE 15 1/2" BOQ. 2", 2 1/4", 2 1/2"

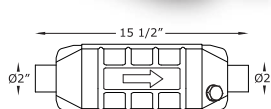

C-I-2504R/05R/06R

REDONDO, LARGO TOTAL DE 15 1/2" BOQ. 2", 2 1/4", 2 1/2"

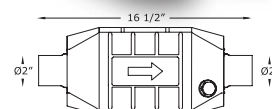

C-I-2514/15/16/17

OVALADO, LARGO TOTAL DE 16 1/2" BOQ. 2", 2 1/4", 2 1/2", 3"



NO. DE PARTE CUERPO/LARGO TOTAL BOQUILLAS

PB-3012	3" X 12"	15"	1 3/4" D.E.
PB-3015	3" X 15"	18"	1 3/4" D.E.
PB-3018	3" X 18"	21"	1 3/4" D.E.
PB-3022	3" X 22"	25"	1 3/4" D.E.
PB-3510	3 1/2" X 10"	13"	1 1/2" D.E.
PB-3512	3 1/2" X 12"	15"	2" D.E.
PB-3515	3 1/2" X 15"	18"	2 1/4" D.E.
PB-3518	3 1/2" X 18"	21"	2 1/4" D.E.
PB-3523	3 1/2" X 23"	26"	2 1/4" D.E.
PB-3530	3 1/2" X 30"	33"	2 1/4" D.E.

DEPORTIVO

Ø 3" y 3 1/2", Cal. 16 con pintura electrostática - fibra convencional

NO. DE PARTE CUERPO/LARGO TOTAL BOQUILLAS

PT-3012	3" X 12"	15"	1 3/4" D.E.
PT-3015	3" X 15"	18"	1 3/4" D.E.
PT-3018	3" X 18"	21"	1 3/4" D.E.
PT-3022	3" X 22"	25"	1 3/4" D.E.
PT-3512	3 1/2" X 12"	15"	2 1/4" D.E.
PT-3515	3 1/2" X 15"	18"	2 1/4" D.E.
PT-3518	3 1/2" X 18"	21"	2 1/4" D.E.
PT-3523	3 1/2" X 23"	26"	2 1/4" D.E.
PT-3530	3 1/2" X 30"	33"	2 1/4" D.E.

MOFLE DEPORTIVO

Ø 3" y 3 1/2", Cal. 16 con pintura electrostática - sin fibra



NO. DE PARTE CUERPO/LARGO TOTAL BOQUILLAS

PL-3012	3" X 12"	15"	1 3/4" D.E.
PL-3015	3" X 15"	18"	1 3/4" D.E.
PL-3018	3" X 18"	21"	1 3/4" D.E.
PL-3022	3" X 22"	25"	1 1/2" D.E.
PL-3024	3" X 24"	27"	1 3/4" D.E.
PL-3512	3 1/2" X 12"	15"	2 1/4" D.E.
PL-3515	3 1/2" X 15"	18"	2 1/4" D.E.
PL-3518	3 1/2" X 18"	21"	2 1/4" D.E.
PL-3522	3 1/2" X 22"	27"	2 1/4" D.E.
PL-3530	3 1/2" X 30"	33"	2 1/4" D.E.

RESONADOR

Ø 3 y 3 1/2", Cal. 16 galvanneal sin pintura, tubos interior de 1 3/4" y 2 1/4" cal. 16 galvanneal, escama en espiral doble sentido, fibra de vidrio americana

NO. DE PARTE CUERPO/LARGO TOTAL BOQUILLAS

PR-2508	2 1/2" X 8"	11"	1 3/4" D.I.
PR-2510	2 1/2" X 10"	13"	1 3/4" D.I.
PR-2512	2 1/2" X 12"	15"	1 3/4" D.I.
PR-2515	2 1/2" X 15"	18"	1 3/4" D.I.

RESONADOR / ESPECIAL PARA COMPACTOS

Ø 2 1/2", Cal. 16 galvanneal sin pintura, tubos interior de 1 3/4" cal. 16 galvanneal, escama en espiral un sentido, fibra de vidrio americana



NO. DE PARTE	CUERPO/LARGO	TOTAL	BOQUILLAS	NO. DE PARTE	CUERPO/LARGO	TOTAL	BOQUILLAS
PS-4010	4" X 10"	13"	2 ¼" D.E.	PS-4018	4" X 18"	21"	2 ¼" D.I.
PS-4012	4" X 12"	15"	2 ¼" D.I.	PS-4022	4" X 22"	25"	2 ¼" D.I.
PS-4015	4" X 15"	18"	2 ¼" D.I.				

DEPORTIVO

Ø 4", Cal. 16 con pintura electrostática - fibra convencional

COLILLAS CROMADAS



NO. DE PARTE	DESCRIPCIÓN	PULG.	MTS.	Ø	CAL.	CALIDAD
KCC-200	COLILLA CURVA DE 2"	8.75	.22	2"	16	B.T.P
KCC-212	COLILLA CURVA DE 2 ½"	9.00	.23	2 ½"	16	B.T.P
KCR-3012	COLILLA RECTA DE EXPORTACIÓN	12.00	.30	3"	16	B.T.P
KCR-3016	COLILLA RECTA DE EXPORTACIÓN	16.00	.41	3"	16	B.T.P
KCR-3018	COLILLA RECTA DE EXPORTACIÓN	18.00	.46	3"	16	B.T.P
KCR-3024	COLILLA RECTA DE EXPORTACIÓN	23.87	.61	3"	16	B.T.P
KCR-31212	COLILLA RECTA DE EXPORTACIÓN	12.00	.30	3 ½"	16	B.T.P
KCR-31216	COLILLA RECTA DE EXPORTACIÓN	16.00	.41	3 ½"	16	B.T.P
KCR-31218	COLILLA RECTA DE EXPORTACIÓN	18.00	.46	3 ½"	16	B.T.P
KCR-31222	COLILLA RECTA DE EXPORTACIÓN	22.00	.56	3 ½"	16	B.T.P
KCR-4022	COLILLA RECTA DE EXPORTACIÓN	21.50	.55	4"	16	B.T.P

COLILLAS

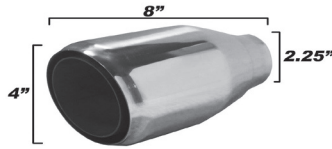

**R-008 N
DOBLE PARED**

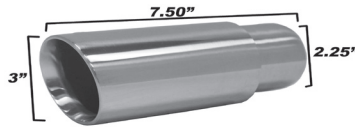

**R-013 A
DOBLE PARED**

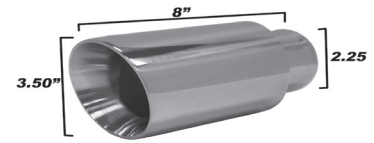

**R-013 B
DOBLE PARED**

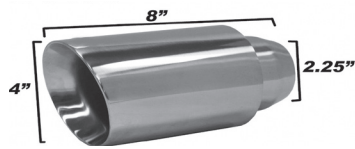

**R-013 C
DOBLE PARED**

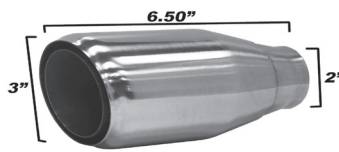

**R-015
DOBLE PARED - RESONADOR**

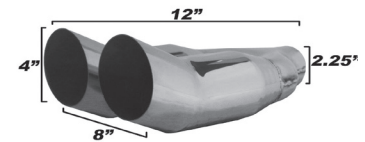

R-025 N

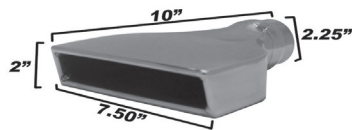

R-027 S

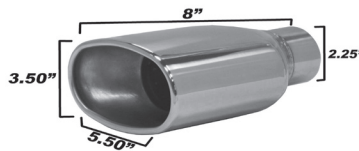

**R-039 A
RESONADOR**

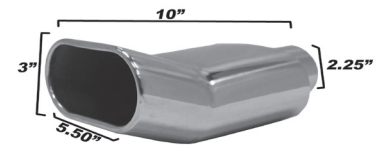

R-043

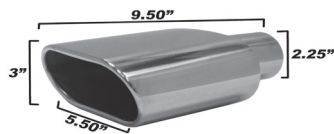

R-043 S

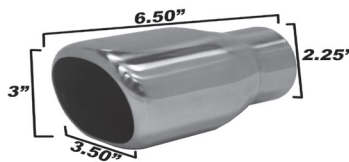

**R-047
DOBLE PARED**

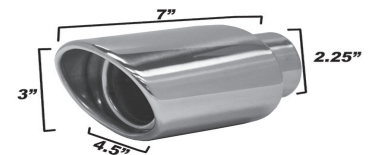

**R-062
RESONADOR**

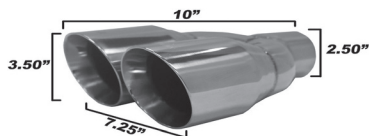

**R-253510D
DOBLE PARED**

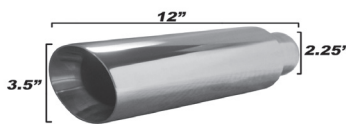

**R-24013B-12
DOBLE PARED**

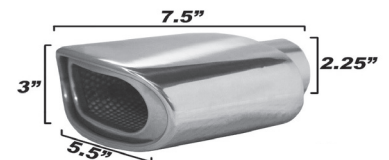

**R-311
RESONADOR**

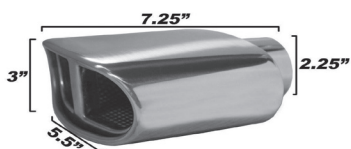

**R-312
RESONADOR**

STAINLESS STEEL 304
ACERO INOXIDABLE 304
HIGH QUALITY
ALTA CALIDAD

PERFORMANCE
DESEMPEÑO
RACING SOUND
SONIDO DEPORTIVO



NO. DE PARTE	DESCRIPCIÓN
A9101-13/4	T.I. CHEVY SWING JOY 95-99
A9102-21/2	T.C. CTA CHEV. PICK UP
A9492D-21/4	T.C. CHEVROLET 92-98 DER
A9492I-21/4	T.C. CHEVROLET 92-98 IZQ
A9115-13/4	T.I. TORNADO 04
A9114-2-16	T.I. CORSA
C7810-21/2	T.C. CTA FORD LOBO
C037-2-16	T.C. CTA FORD RANGER AMERICANA
C9801-2-16	TUBO DE COLA CAMIONETA PICK UP RANGER
C045-216	TUBO INTERMEDIO CON ENSAMBLE ECOSPORT
C031-21/4D	T.C. CTA FORD TODOS
C031-2-16D	T.C. CTA FORD TODOS
C039-3-14	T.C. CAMION TRITON 2003
C047-13/4	T.I. FIESTA 2004
C042-13/4	TUBO INTERMEDIO DE COURRIER
E145-2-16	T.C. NISSAN U.S.A
G2001-2-16	T.I. POINTER
N8900-13/4	T.I. PEUGEOT

*T.D. TUBO DELANTERO *T.I. TUBO INTERMEDIO *T.C. TUBO DE COLA *CTA CAMIONETA

*****Se fabrican mas de 200 modelos de tubería sobre pedido para que ya pases el catálogo para autorización.**

TUBERÍA RECTA



Diámetro: 1 1/2", 1 3/4", 2", 2 1/4", 2 1/2", 3" Cal. 16

Venta por metros, máximo tramos de 6 metros
calibres y diámetros no incluidos

***Se manejan sobre pedidos**

AROS DE TUBOS DE ESCAPE

NO. DE PARTE	DESCRIPCIÓN
E-LA-05100	EMPAQUE GM, CHEVY, MONZA, POP
E-LA-05105	EMPAQUE AMERICAN MOTORS S4 1983 GM
E-LA-05115-G	EMPAQUE CHEVR 6 V8, 84-85, FORD 6 V8
E-LA-05115-M	EMPAQUE FORD, GM, JEEP, EAGLE 4 151
E-LA-05130-G	EMPAQUE CHEVR6, MAQ3, 292V8 MARQUIS
E-LA-05140	EMPAQUE AMC, GM, JEEP, EANGLE 4,6,8
E-LA-05140-CF	EMPAQUE GM, 121, 89-89 134
E-LA-05160	EMPAQUE GM, V6, 262, 43L, 50L, 250
E-LA-05160-1	EMPAQUE GM, V8, ISUCO V8 350 366
E-LA-05160-3	EMP. CHEV. V8 VORTEC V6 96-09 SUBURBAN, SILVERADO, CHEYENNE
E-LA-05240-G	EMPAQUE CHR, 4(1,6,1,7,2,2,2,6L) 1980-1995
E-LA-05240-M	EMPAQUE CHR, RENAULT, SHADOW, SPIRIT
E-LA-05242	EMPAQUE CHR, NEON, STRATUS
E-LA-05253	EMP. CHR. V6 181 MOT. MITSUBISHI
E-LA-05355	EMPAQUE FORD, V6, 352, 359, 360, 390, 361, 391
E-LA-05710	EMPAQUE RAMBLER DINA-WILLIS 6
E-LA-51225	EMPAQUE NISSAN 4 MOTOR, 2.4L
E-LA-51226	EMPAQUE NISSAN 4 MOTOR 1.6 L GA16
E-LA-51400	EMPAQUE OPEL 4 1500, 1700, DATSUN
E-LA-51800	EMPAQUE VW, 1200, 1500, 1600, 1954-96
E-LA-51840	EMPAQUE AUDI, VW4 (1.6, 1.7, 1.7L)

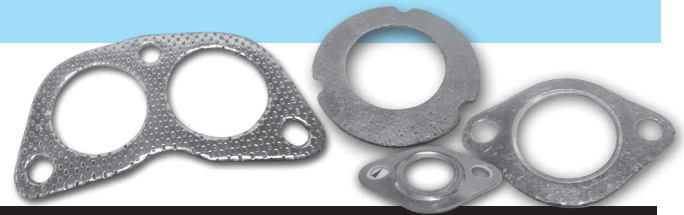
ACCESORIOS PARA MOTORES DE GASOLINA

NO. DE PARTE	DESCRIPCIÓN
E-LB-051218-1	EMPAQUE NISSAN-DATSUN 4, MOTOR CA ET
E-LB-05152	EMPAQUE CHEV. V8 (TRIANG) D.I. 21/8 57/84
E-LB-05200	EMPAQUE CHR. DODGE 6 1934/88 WILLIS
E-LB-05200-S	EMPAQUE CHR. 6 1933/93, WILLYS, 6 (BLINDADA)
E-LB-05240-M	EMPAQUE CHR. RENAULT, 4.6 1.6L 1.7 2.2
E-LB-05253	EMPAQUE CHR. V6 181 MOTOR MITSUBISHI
E-LB-05300	EMPAQUE FORD 4 140 TOPAZ 1985/94
E-LB-05310	EMPAQUE FORD 6 Y V8 1949/67

E-LB-41810	EMPAQUE V.W. TODOS
E-LB-41811	EMPAQUE V.W. 1200, 1500, 1600
E-LB-51216	EMPAQUE NISSAN 4 1.6L TSU - TRI
E-LB-51218	EMPAQUE NISSAN, DATSUN 4 MOT L1.6 - L1.8
E-LB-51218-1	EMPAQUE NISSAN DATSUN 4; MOTOR CA 18 ET
E-LB-51222	EMPAQUE NISSAN, DATSUN 4 MOT. CA 16D CA
E-LB-51225	EMPAQUE NISSAN 4 MOT 2.4L K24E PICK UP
E-LB-51310	EMPAQUE TOYOTA 4, 2.2., 2.4 2OR 22R
E-LB-51310-1	EMPAQUE CHEV. GEO 1985/92 TOYOTA
E-LB-51310-2	EMPAQUE CHEVY GEO 1985/92 TOYOTA 1.6
E-LB-51810	EMPAQUE V.W. 4 TODOS 1500, 1600
E-LB-51811	EMPAQUE V.W., 1200, 1500, 1600
E-LB-51830	EMPAQUE V.W., CARIBE, ATLANTIC, GOLF
E-LB-51840	EMPAQUE V.W. RECTANGULAR
E-LB-51840-1	EMPAQUE V.W. RECTANGULAR
E-LB-51840-2	EMPAQUE V.W. RECTANGULAR
E-LB-51845	EMPAQUE VW., GOLF, JETTA
E-LB-5200-S	EMPAQUE CHR. 1993/90 WILLYS 6 (BLINDADA)



SOPORTES DE HULE

NO. DE PARTE	
S-GAP-0004	SOPORTE MINI COOPER TRASERO DEL 2000 EN ADELANTE
S-GAP-0008	SOPORTE JETTA, PASSAT, BEETLE
S-GAP-0009	SOPORTE BEETLE, JETTA A4, PASSPORT
S-GAP-0010	SOPORTE GOLF, JETTA 93-99
S-GAP-0020	SOPORTE JETTA A3
S-GAP-0020-L	SOPORTE JETTA A4, BEETLE, PASSAT
S-GAP-0030	SOPORTE GOLF JETTA A3
S-GAP-0040	SOPORTE DONA, JETTA, GOLF
S-GAP-0050	SOPORTE GALLETA CARIBE, ATLANTIC
S-GAP-0060	SOPORTE TSURU I, TSURU II
S-GAP-0070	SOPORTE TSURU III, SENTRA
S-GAP-0080	SOPORTE TSURU III, SENTRA

NO. DE PARTE	DESCRIPCIÓN
S-GAP-0085	SOPORTE X-TRAIL 03, SENTRA 03
S-GAP-0086	SOPORTE URBAN DEL 2003-2007
S-GAP-0087	SOPORTE TRASERO PARA CLIO Y PLATINA
S-GAP-0088	SOPORTE PARA CLIO INTERMEDIO
S-GAP-0090-1/2	SOPORTE CIVIC Y ACCORD 2004-2007
S-GAP-0090-3/8	SOPORTE CIVIC Y ACCORD 1997-2003
S-GAP-0091	SOPORTE CR-V, PILOT, ODYSSEY 2000-2003
S-GAP-0092	SOPORTE PILOT 2004-2007
S-GAP-0100	SOPORTE INT DART K, SPIRIT
S-GAP-0110	SOPORTE GRAD CHEROKEE 97-98
S-GAP-0120	SOPORTE STRATUS, CIRRUS
S-GAP-0150	SOPORTE NEON
S-GAP-0155	SOPORTE NEON 2002-2005
S-GAP-0160	SOPORTE RAM 1500, 3500, 4000, VOYAGER
S-GAP-0200	SOPORTE TRASERO SHADOW, SPIRIT
S-GAP-0300	SOPORTE TRASERO DART K, VOLARE
S-GAP-0350	SOPORTE TRASERO CAMARO, PICK-UP
S-GAP-0400	SOPORTE COUGAR VIEJO Y TOPAZ
S-GAP-0450	SOPORTE LOBO F550, F250, F150
S-GAP-0500	SOPORTE TOPAZ, GHIA, TAURUS, COUGAR
S-GAP-0510	SOPORTE MYSTIQUE, WINDSTAR, ESCORT, CONTUR
S-GAP-0515	SOPORTE FIESTA IKON, COURIER
S-GAP-0516	SOPORTE INTERMEDIO CTA PICK UP
S-GAP-0520	SOPORTE FOCUS 2000
S-GAP-0600	SOPORTE THUNDERBIRD, COUGAR
S-GAP-0700	SOPORTE THUNDERBIRD, COUGAR
S-GAP-0800	SOPORTE CAVALIER Z24, CUTLAS, CENTURY
S-GAP-0805	SOPORTE I. CAVALIER DE 1995 AL 2002
S-GAP-0810	SOPORTE CAVALIER TRASERO DEL 2000-2005
S-GAP-0850	SOPORTE TRASERO DE CHEVY MONZA
S-GAP-0860	SOPORTE CHEVY PICK UP
S-GAP-0861	SOPORTE CHEVY PICK UP
S-GAP-0862	SOPORTE ASTRA
S-GAP-0863	SOPORTE SUBURBAN CHEYENNE
S-GAP-0864	SOPORTE CTA PICK UP, S-10, 4 Y 6 CIL
S-GAP-0890	SOPORTE CTA. MALIBU, TRASERO 2002-ADELANTE

NO. DE PARTE	DESCRIPCIÓN
S-GAP-0900	SOPORTE TRASERO CELEBRITY, CENTURY
S-GAP-0910	SOPORTE PEUGEOT, 206-306
S-GAP-0950	SOPORTE RENAULT MEGANE
S-GAP-0951	SOPORTE PARA CAMIONETA KANGOO
S-GAP-1000	SOPORTE COMBI 1800 MOD 88-96



ABRAZADERAS GASOLINA

NO. DE PARTE	DESCRIPCIÓN
J ACS-112	ABRAZADERA TIPO U 1½ CS
J ACS-134	ABRAZADERA TIPO U 1 3/4" CS
J ACS-200	ABRAZADERA TIPO U 2" CS
J ACS-212	ABRAZADERA TIPO U 2½" CS
J ACS-214	ABRAZADERA TIPO U 2¼" CS
J ACS-300	ABRAZADERA TIPO U 3" CS
J ACS-312	ABRAZADERA TIPO U 3½" CS
J ATU-112	ABRAZADERA TIPO U 1½ SS
J ATU-134	ABRAZADERA TIPO U 1 3/4" SS
J ATU-200	ABRAZADERA TIPO U 2" SS 1
J ATU-212	ABRAZADERA TIPO U 2½" SS
J ATU-214	ABRAZADERA TIPO U 2¼" SS
J ATU-300	ABRAZADERA TIPO U 3" SS
J ATU-312	ABRAZADERA TIPO U 3½" SS
J ATU-400	ABRAZADERA TIPO U 4" SS 63.36
J ATU-500	ABRAZADERA TIPO U 5" SS 74.03
J ATUN-CS	ABRAZADERA UNIVERSA CON SOPORTE
J-GANCHO-12	ABRAZADERA CON GANCHO DE 12"
J-GANCHO-6	ABRAZADERA CON GANCHO DE 6"
J-GANCHO-9	ABRAZADERA CON GANCHO DE 9"

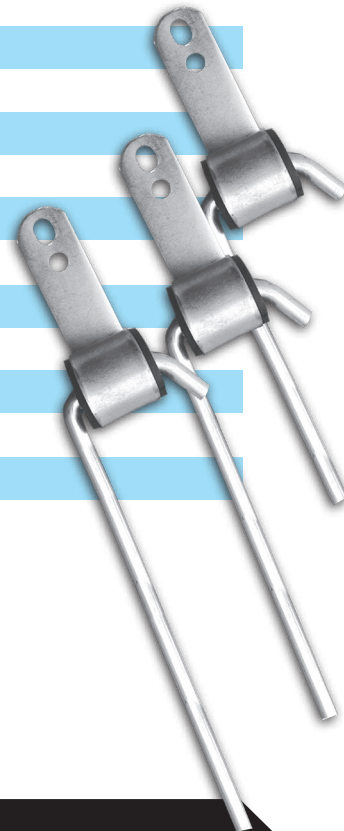



ABRAZADERAS LÍNEA PESADA

NO. DE PARTE	DESCRIPCIÓN
EMLP-AGMC-3	ABRAZADERA GMC 3"
EMLP-AGMC-3½	ABRAZADERA GMC 3½"
EMLP-AGMC-4	ABRAZADERA GMC 4"
EMLP-AGMC-4½	ABRAZADERA GMC 4½"
EMLP-ATURBO-5	ABRAZADERA TURBO 5"
EMLP-ADINA-4	ABRAZADERA DINA 4"
EMLP-ADINA-4½	ABRAZADERA DINA 4½"
EMLP-ACESC-3	ABRAZADERA CINCHO ESC 3"
EMLP-ACESC-3½	ABRAZADERA CINCHO ESC 3½"
EMLP-ACESC-4	ABRAZADERA CINCHO ESC 4"
EMLP-ACESC-5	ABRAZADERA CINCHO ESC 5"
EMLP-ACESC-AM3	ABRAZADERA CINCHO ESC AMR 3"
EMLP-ACESC-AM3½	ABRAZADERA CINCHO ESC AMR 3½"
EMLP-ACESC-AM4	ABRAZADERA CINCHO ESC AMR 4"
EMLP-ACESC-AM5	ABRAZADERA CINCHO ESC AMR 5"
EMLP-ACLISA-4	ABRAZADERA CINCHO LISA 4"
EMLP-ACLISA-5	ABRAZADERA CINCHO LISA 5"
EMLP-AT693-4½	ABRAZADERA TURBO 693 4½"
EMLP-AT692-5	ABRAZADERA TURBO 692 5"
EMLP-ATPTA-2½	ABRAZADERA TURBO PLATA 2 ½"
EMLP-ATPTA-2¼	ABRAZADERA TURBO PLATA 2 ¼"

ABRAZADERAS DE MANGUERAS



NO. DE PARTE	DESCRIPCIÓN
EMLP-ABRAM 3	ABRAZADERA PARA MANGUERA 3"
EMLP-ABRAM 3 ½	ABRAZADERA PARA MANGUERA 3½"
EMLP-ABRAM 4	ABRAZADERA PARA MANGUERA 4"
EMLP-ABRAM 4 ¼	ABRAZADERA PARA MANGUERA 4¼"
EMLP-ABRAM 4 ½	ABRAZADERA PARA MANGUERA 4½"
EMLP-ABRAM 5	ABRAZADERA PARA MANGUERA 5"

CONEXIONES PARA SISTEMAS DE ESCAPE

NO. DE PARTE	DESCRIPCIÓN
FLX-1-3/4X4 CB	FLEXIBLE DE 1 3/4" X 4" C/BOQ
FLX-1-3/4X6 CB	FLEXIBLE DE 1 3/4" X 6" C/BOQ
FLX-1-3/4X8 CB	FLEXIBLE DE 1 3/4" X 8" C/BOQ
FLX-2X4 CB	FLEXIBLE DE 2" X 4" C/BOQ
FLX-2X6 CB	FLEXIBLE DE 2" X 6" C/BOQ
FLX-2X8 CB	FLEXIBLE DE 2" X 8" C/BOQ
FLX-2-1/4X4 CB	FLEXIBLE DE 2 1/4" X 4" C/BOQ
FLX-2-1/4X6 CB	FLEXIBLE DE 2 1/4" X 6" C/BOQ
FLX-2-1/4X8 CB	FLEXIBLE DE 2 1/4" X 8" C/BOQ
FLX-2-1/2X4 CB	FLEXIBLE DE 2 1/2" X 4" C/BOQ
FLX-2-1/2X6 CB	FLEXIBLE DE 2 1/2" X 6" C/BOQ
FLX-2-1/2X8 CB	FLEXIBLE DE 2 1/2" X 8" C/BOQ
FLX-3X6 CB	FLEXIBLE DE 3" X 6" C/BOQ
FLX-STRATUS	FLEXIBLE PARA STRATUS C/BOQ

Absorbe la vibración e impacto de la tubería y el silenciador evitando fracturas

CARACTERÍSTICAS:

- 1) Fabricado con tubo interior de acero inoxidable.
- 2) Trenza de acero en el exterior e interior.
- 3) Boquillas de lámina aluminizada de fácil soldadura.



CEMENTO PARA MOFLES



MEN-CM1



SOLDADURA AUTOGENA

VARILLA APORTE 1/8", 2 KG.



CA-NS



SUCURSALES Y DISTRIBUIDORES

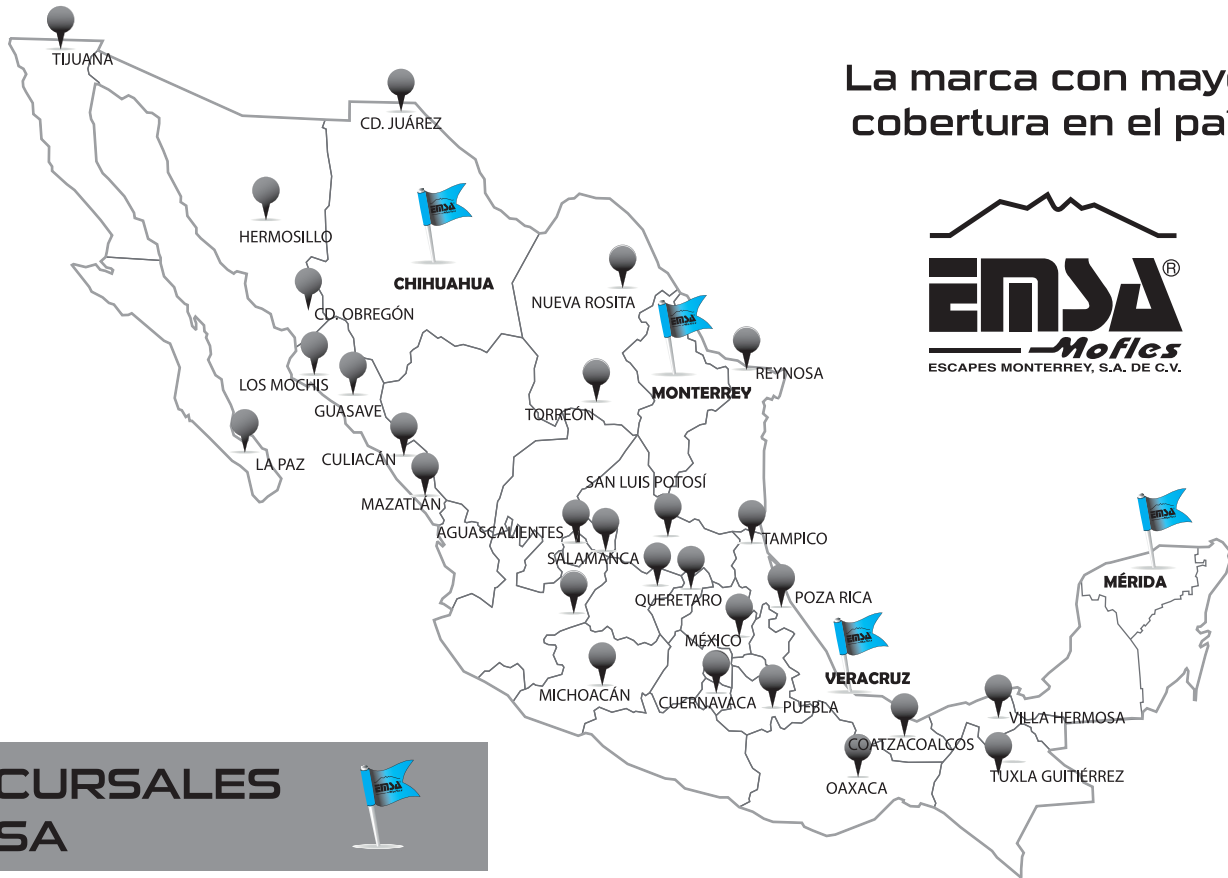

La marca con mayor
cobertura en el país



SUCURSALES EMSA



MATRIZ MONTERREY

Av. Internacional No. 304
Co. Parque Industrial Huinalá,
Apodaca, N.L. C.P. 66645
Tel. (81) 8196.9700 (con 60 líneas)

TRIUNFO MOFLES MTY.

Av. Miguel Alemán No. 4333 Ote.
Col. Churubusco, Monterrey, N.L.
C.P. 64590 México
Tels. (81) 8355.4464 / 8355.5574

VERACRUZ

Cauhtémoc No. 3971
entre Sánchez Tagle y Campero
Centro, Veracruz, Veracruz, C.P. 91700
Tel. (01) 2299.3862.27

MÉRIDA

Calle 103 No. 505 entre 62 A Y 62 B
Col. Delio Moreno Cantón
Mérida, Yucatán, C.P. 97248
Tels. (999) 2868.438 / 2908.368

CHIHUAHUA

Gabino Barrera No. 4115,
Col. Granjas, Chihuahua, Chihuahua C.P. 31100
Tel. (614) 4386.217

DISTRIBUIDORES EMSA



- Aguascalientes
- Cd. Obregón
- Cd. Juárez
- Chihuahua
- Coahuila
- Cuernavaca
- Culiacán
- Guadalajara
- Guasave
- Hermosillo
- La Paz
- Los Mochis
- Mazatlán
- México
- Morelia
- Nueva Rosita
- Oaxaca
- Poza Rica
- Puebla
- Querétaro
- Reynosa
- Salamanca
- San Luis Potosí
- Tampico
- Tijuana
- Torreón
- Tuxtla Gutierrez
- Villa Hermosa

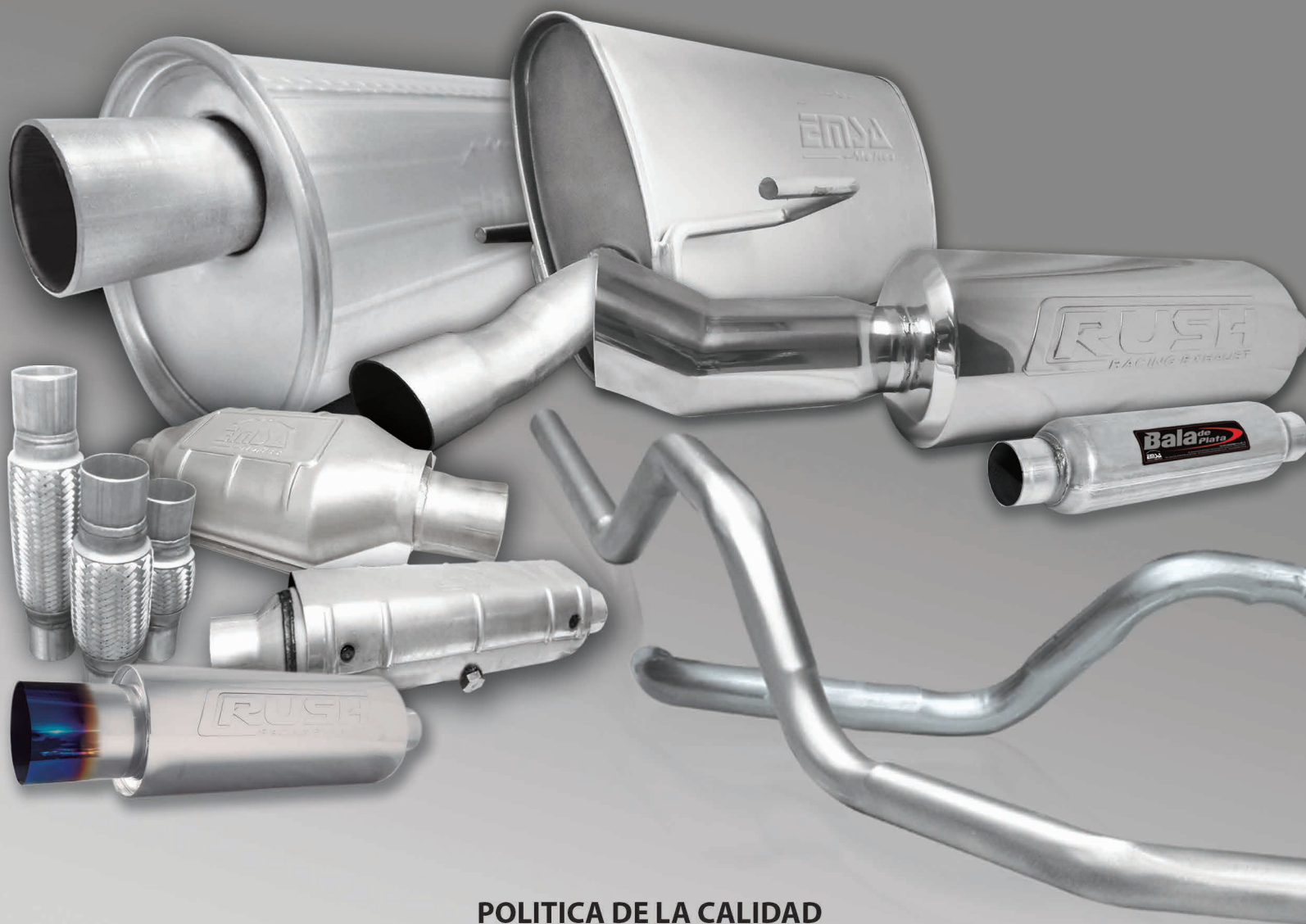

POLITICA DE LA CALIDAD

La alta dirección y el personal de ESCAPES MONTERREY S.A. DE C.V., estamos comprometidos a satisfacer los requerimientos de nuestros clientes en la fabricación de sistemas de escape para vehículos automotores, con tecnología de vanguardia, manteniendo una alta competencia de nuestro personal y mejorando en forma continua la eficacia de nuestro Sistema de Gestión de Calidad, basado en la norma ISO 9001:2015



DISTRIBUIDO POR:

www.emsamofles.com.mx

**Ave. Internacional 304, Col. Parque Industrial Huinalá
Apodaca, N.L. México C.P. 66645
Tel. com. (81) 8196.9700 (con 60 líneas)
Fax: (81) 8196.9729**